

**ANEXO 1: BOMBA RECIPROCANTE DE ÉMBOLOS TRÍPLEX CAT  
PUMPS 3801KM.CO2 [TECNIFLOW, 2013], [CAT PUMPS, 2009], [CAT  
PUMPS, 2011]**

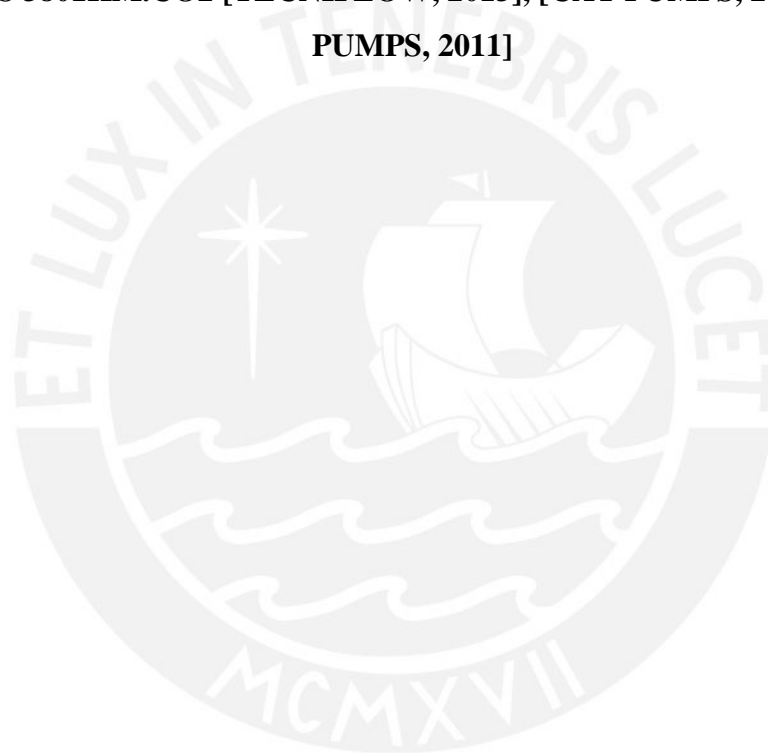



**Tecniflow**  
Especialistas En Control de Fluidos

Lima, 27 de Mayo de 2013  
TF-CBR0884/13

Señores  
**ALICORP**  
Presente.-

Atención : Ing. Jorge Jonatan O. Vivar Calle

Referencia : Bomba alta presión CAT

Estimados señores:

Muy cordialmente nos dirigimos a ustedes con la finalidad de saludarlos y hacerles llegar nuestra cotización por los siguientes productos:

ITEM	CANT.	DESCRIPCION	VALOR UNITARIO US\$
1	1	<b>BOMBA DESPLAZAMIENTO POSITIVO</b> <b>TIPO PISTONES DE ALTA PRESION</b> Marca : CAT PUMPS Procedencia : USA Modelo : 3801KM.CO2 <u>Características:</u> Manifolds : Acero Inoxidable Válvulas y asientos : Acero Inoxidable Émbolos : Acero Inoxidable Carcasa : Fundición de aluminio de alta resistencia Cigüeñal : Cromado para alta dureza Rodamientos : Acero Succión / Descarga : 1 1/2" - 1" NPT <u>Condiciones de Operación:</u> Fluido : CO2 Caudal : 5 LPM Presión de Descarga : 220 Bar Presión de Succión : 67 Bar <u>Incluye:</u> Motorreductor Standard de 12.5 HP, 220-440 VAC, 3 fases, 1750/228rpm Placa Base en Acero Estructural, Acoplamiento Flexible Guarda Protectora	38,040.00

PRECIOS NO INCLUYEN IGV

Condiciones Comerciales:

Garantía de 12 meses

Plazo de entrega : De 08-10 semanas en sus almacenes de Lima  
 Forma de Pago : Factura 30 días  
 Validez de la oferta : 30 días

Atentamente:

Ing. Fernando Aliaga J.  
e-mail: faliaga@tecniflow.com.pe

Ing. Jesus Acevedo P.  
e-mail: jacevedo@tecniflow.com.pe

Srta. Yunn Rospigliosi  
Representante de Ventas  
e-mail: ventas4@tecniflow.com.pe

Carlos Cobilich N° 104  
San Borja, Lima 41 - Perú  
P.O.Box 41-0093  
Telts: (51-1) 346-2102 / 346-0189  
Fax: (51-1) 346-2101  
tecniflow@tecniflow.com.pe  
[www.tecniflow.com](http://www.tecniflow.com)

# CO2 PUMPING SOLUTIONS



## Industrial duty pumps for liquid CO2 applications

Liquid Carbon Dioxide has unique properties that are beneficial in oil and gas, pharmaceutical, manufacturing and processing industries. Although the implication of CO2 into production processes in some applications is still very new, many applications have been pumping liquid CO2 for years.

For over 20 years, Cat Pumps has provided dependable liquid CO2 pumping solutions. We've worked closely with research facilities, universities, equipment manufacturers and site locations to develop reliable pumping solutions in challenging CO2 applications.

### Typical Applications

- Enhanced Oil Recovery
- Chemical-Free Cleaning
- Storage and Transfer
- Lipid Extraction
- Carbon Sequestration
- Machine Tool Cooling
- Foam and Gel Manufacturing
- Coal Bed Methane Recovery

### Features

- Output ranges from .75 – 48 gpm at 300 – 5000 psi
- Reinforced internal components designed for high inlet pressure
- Inverted manifold to prevent vapor entrapment
- Special seals designed for cold temperature
- Optional Glycol flushing to prevent freezing
- Field-proven dependability



**Benefits of using Cat Pumps for your CO2 needs include:**

- 20 years of experience pumping CO2
- Live Technical Support
- Pump repair parts in stock
- Fast delivery on pumps and systems

MODEL	FLOW*			PRESSURE*
	(gpm)	(kg/hr)	(lbs/hr)	(psi)
7B4KM.CO2	0.34	81	189	5000
30RS.CO2	0.68	162	378	2200
30L.CO2	0.68	162	378	2150
781KM.CO2	0.82	196	456	5000
781KMRS.CO2	0.82	196	456	5000
5CP2921	1.7	406	945	2500
310.CO2	1.75	418	973	2200
3801KM.CO2	3.5	836	1946	5000
1051CM.CO2	4.0	955	2224	2000
1530RSCM.CO2	5.0	1194	2780	1800
1951	5.0	1194	2780	1450
6811KM.CO2	7.2	1719	4003	5000
2831K.CO2	10.0	2388	5560	1200
3520CM.CO2	11.4	2722	6338	2000
6821KM.CO2	16.0	3821	8896	3000
3535CM.CO2	19.4	4633	10786	1200
3831KM.CO2	19.4	4633	10786	1200
6841KM.CO2	30.0	7164	16680	2000
6861KM.CO2	50.0	11940	27800	1200
6841KM.CO2	32.0	7685	16905	2000
6861KM.CO2	48.0	11465	25225	1200

\* Flow and pressure may vary based on inlet/temp. conditions. Custom flows and pressures available upon request.

**For more information on CO2 pumps and accessories, contact Cat Pumps.**

**CAT PUMPS**  
 1681 94th Lane NE, Minneapolis, MN 55449  
 Phone: 763.780.5440 Fax: 763.780.2958 e-mail: techsupport@catpumps.com www.catpumps.com  
©2011 Cat Pumps. All rights reserved. 062301 Rev. B 1/11





## 38 Frame Block-Style Stainless Steel Plunger Pump

**Standard Models 3801, 3811**

**Flushed Models 3801K, 3811K**

### FEATURES

#### Superior Design

- Triplex plunger design provides smoother liquid flow.
- Oil bath crankcase assures optimum lubrication.
- Close tolerance concentricity of the ceramic plunger maximizes seal life.
- **Standard Models:** Lo-Pressure Seals and V-Packings are completely lubricated and cooled by the liquid being pumped.
- **K Models:** Special Flushed Inlet Manifold permits flush for added cooling with high temperature liquids and lubrication with low lubricity liquids.

#### Quality Materials

- Precision design 316 stainless steel valves and seats are hardened and polished for ultimate seating and extended valve life.
- 316 SSL block-style manifolds for strength and corrosion resistance.
- Special concentric, high-density, polished, solid ceramic plungers provide a true wear surface and extended seal life.
- Specially formulated, CAT PUMP exclusive, V-Packings offers unmatched performance and seal life.
- Die cast aluminum crankcase provides high strength, minimum weight and precision tolerance control.
- Optional Cast Iron crankcase for hazardous environments.
- Chrome-moly crankshaft gives unmatched strength and surface hardness.
- Oversized crankshaft bearings with greater capacity means longer bearing life.

#### Easy Maintenance

- Wet-end is easily serviced without entering crankcase, requiring less time and effort.
- Inlet and discharge valve assemblies interchange for easier maintenance without disturbing piping.
- Preset packings mean no packing gland adjustment is necessary, reducing maintenance costs.

**WARNING**  
All systems require both a primary pressure regulating device (i.e., regulator, unloader) and a secondary pressure safety relief device (i.e., pop-off valve, safety valve). Failure to install such relief devices could result in personal injury or damage to the pump or to system components. CAT PUMPS does not assume any liability or responsibility for the operation of a customer's high pressure system.

### SPECIFICATIONS

U.S. Measure      Metric Measure

#### MODEL 3801, 3801K

Flow	9.0 GPM	(34 L/M)
Pressure Range	100 to 5000 PSI	(7 to 345 BAR)
RPM	824 RPM	(824 RPM)
Bore	0.787"	(20 mm)

#### MODEL 3811, 3811K

Flow	14 GPM	(53 L/M)
Pressure Range	100 to 3000 PSI	(7 to 210 BAR)
RPM	800 RPM	(800 RPM)
Bore	0.984"	(25 mm)

#### COMMON SPECIFICATIONS

Inlet Pressure*	Flooded to 70 PSI	(Flooded to 4.9 BAR)
Stroke	1.890"	(48 mm)
Crankcase Capacity	4.2 Qts.	(4 L)
Maximum Liquid Temperature	160°F	(71°C)

Above 130°F call CAT PUMPS for inlet conditions and elastomer recommendations.

Inlet Ports (2)	1-1/2" NPTF	(1-1/2" NPTF)
Flushing Ports (2)	1/2" NPTF	(1/2" NPTF)
Discharge Ports (2)	1" NPTF	(1" NPTF)
Pulley Mounting	Either Side	(Either Side)
Shaft Diameter	1.378"	(35 mm)
Weight	170 lbs.	(77 kg)
Dimensions	24.72 x 18.11 x 9.37"	(628 x 460 x 238 mm)

\* K Models: Special Flushed Inlet Manifold permits external flush for added cooling with high temperature liquids and lubrication with low lubricity liquids.

### ELECTRIC HORSEPOWER REQUIREMENTS

MODEL	FLOW		PRESSURE							RPM
	U.S. GPM	L/M	PSI 2000	PSI 2500	PSI 3000	PSI 3500	PSI 4000	PSI 4500	PSI 5000	
3801	9	34	N/A	N/A	N/A	21.6	24.7	27.8	30.9	824
3801K	8	30	N/A	N/A	N/A	19.2	22.0	24.7	27.5	732
	7	27	N/A	N/A	N/A	16.8	19.2	21.6	24.0	640
3811	14	53	19.2	24.0	28.8	N/A	N/A	N/A	N/A	800
3811K	12	45	16.5	20.6	24.7	N/A	N/A	N/A	N/A	685
	10	38	13.7	17.2	20.6	N/A	N/A	N/A	N/A	571

DETERMINING THE PUMP R.P.M.	Rated G.P.M.	=	"Desired" G.P.M.
DETERMINING THE REQUIRED H.P.	Rated R.P.M.	=	"Desired" R.P.M.
DETERMINING MOTOR PULLEY SIZE	GPM x PSI	=	Electric Brake H. P. Required
	1450	=	H. P. Required
	Motor Pulley O.D.	=	Pump Pulley O.D.
	Pump R.P.M.	=	Motor R.P.M.

See complete Drive Packages (Includes Pulleys, Belts, Hubs, Key) Tech Bulletin 003. Refer to pump Service Manual for repair procedure, additional technical information and pump warranty.

*"Customer confidence is our greatest asset"*

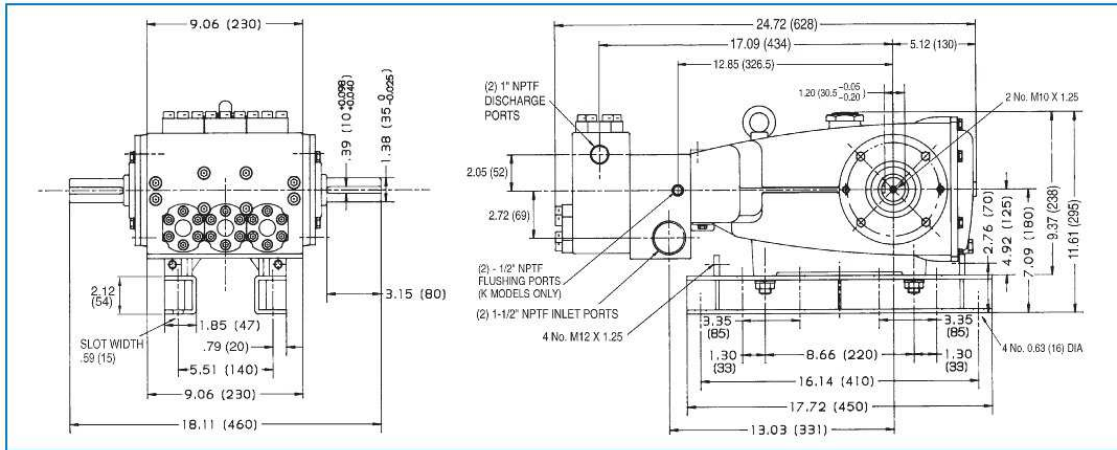

Models 3801, 3801K, 3811, 3811K

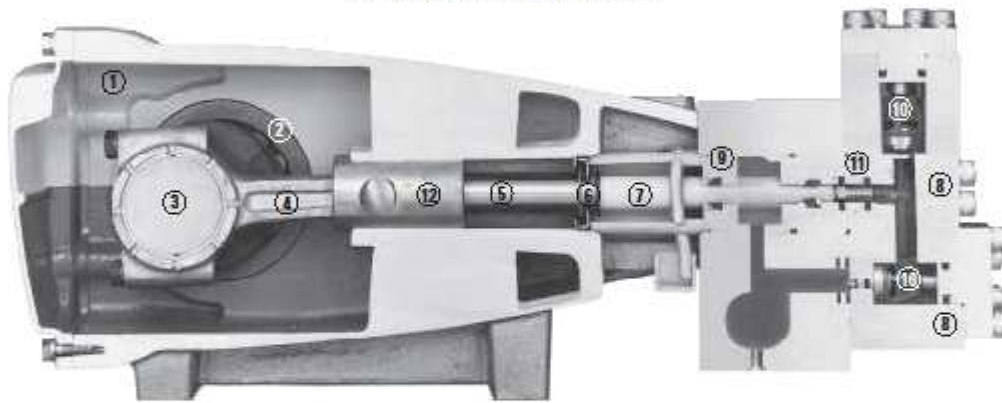

- 1 Die cast aluminum **crankcase** means high strength, lightweight, and excellent tolerance control.
- 2 Oversized crankshaft bearings provide extended bearing life and pump performance.
- 3 Chrome-moly **crankshaft** provides unmatched strength and surface hardness for long life.
- 4 Matched oversized high strength **TNM connecting rods** noted for superior strength and bearing quality.
- 5 Special stainless steel **plunger rods** with high strength crossheads for longevity and corrosion resistance.
- 6 The stainless steel **slinger** provides back-up protection for the crankcase seal, keeping pumped liquids out of the crankcase.
- 7 Special concentric, high-density, polished, solid ceramic **plungers** provide a true wear surface and extended seal life.
- 8 **Manifolds** are 316 SSL block-style for long-term continuous-duty and corrosion resistance.
- 9 **Standard Models:** Lo Pressure Seals and V-Packings are completely lubricated and cooled by the liquid being pumped.
- 9 Special **Flushed inlet Manifold** permits external flush for added cooling with high temperature liquids and lubrication with low lubricity liquids.
- 10 Stainless steel **valves, seats and springs** provide corrosion-resistance, ultimate seating and extended life.
- 11 Specialty formulated, **CAT PUMP** exclusive, **V-Packings** offer unmatched performance and seal life.
- 12 **Crossheads** are 360° supported for uncompromising alignment.

**World Headquarters**  
**CAT PUMPS**  
 1681 - 94th Lane N.E. Minneapolis, MN 55449-4324  
 Phone (763) 780-5440 — FAX (763) 780-2958  
 e-mail: techsupport@catpumps.com  
 www.catpumps.com

**International Inquiries**  
 FAX (763) 785-4329  
 e-mail: intlsales@catpumps.com



**CAT PUMPS (U.K.) LTD.**  
 1 Fleet Business Park, Sandy Lane, Church Crookham  
 FLEET, Hampshire, GU14 0BF, England  
 Phone Fleet 44 1252-820231 — Fax 44 1252-820255  
 e-mail: sales@catpumps.co.uk www.catpumps.co.uk

**N.V. CAT PUMPS INTERNATIONAL S.A.**  
 Havinsdriens 6A, B-2530 Korbich, Belgium  
 Phone 32-3-460.71.00 — Fax 32-3-460.71.01  
 e-mail: cat@catpumps.be www.catpumps.be

**CAT PUMPS DEUTSCHLAND GmbH**  
 Buchwalder 2, D-65110 Idstein, Germany  
 Phone 49 6126-9000 0 — Fax 49 6126-9305 33  
 e-mail: catpumps@l-ortim.de www.catpumps.de

**ANEXO 2: INTERCAMBIADOR DE CALOR DE PLACAS SOLDADAS  
ALFA LAVAL AXP14[ALFA LAVAL]**





## Brazed Plate Heat Exchanger

### Technical Specification

Model : AXP14-24H-F(32871 2840 0)  
 ItemName : Cascade P=1.3kW Date : 24/07/2013  
 Units : 1

side		Hot Side	Cold
		Secondary side	Primary
<b>side(S4)</b>			
Fluid		Carbon dioxide	R134a
Mass flow rate	kg/h	252.0	24.70
Fluid Condensed/Vapourized	kg/h	0.000	17.29
Inlet temperature	°C	20.0	13.3
Dew p.	°C		13.0
Outlet temperature(vapor/liquid)	°C	15.0	17.0
Operating pressure (In/Out)	bara	90.0/90.0	4.62/4.58
Pressure drop	kPa	4.14	4.71
Velocity connection (In/Out)	m/s	0.539/0.517	0.639/2.10
Heat Exchanged	kW	0.9277	
Heat transfer area	m <sup>2</sup>	0.28	
O.H.T.C clean conditions	W/(m <sup>2</sup> *K)	1844	
O.H.T.C service	W/(m <sup>2</sup> *K)	1040	
Fouling resistance * 10000	m <sup>2</sup> *K/W	0.0	
Margin	%	77.4	
Mean Temperature Difference	K	3.4	
Relative direction of the fluids		Countercurrent	
Number of passes		1	1
Material plate / brazing		Alloy 316 / Cu	
Connection S1 (Hot-In)		Soldering/ 7/8" - 28 mm	Sold -
Weld (AX18) Alloy 304			
Connection S2 (Hot-Out)		Soldering/ 7/8" - 28 mm	Sold -
Weld (AX18) Alloy 304			
Connection S3 (Cold-In)		Soldering/ 7/8" - 28 mm	Sold -
Weld (AX18) Alloy 304			
Connection S4 (Cold-Out)		Soldering/ 7/8" - 28 mm	Sold -
Weld (AX18) Alloy 304			
Pressure vessel code		PED 90 degr C	
Designpressure at -196.0 Celsius	Bar	110.	152.
Design pressure at 90.0 Celsius	Bar	110.	152.
Design temperature	°C	-196.0/90.0	
Overall length x width x height	mm	61 x 76 x 190	
Net weight, empty / operating	kg	1.63 / 1.86	
Package length x width x height	mm	x x	
Package weight	kg		
Unit Price			
<b>-Unit</b>	<b>32871 2840 0</b>	<b>USD 1,800 + IGV</b>	

Performance is conditioned on the accuracy of customers data and customers ability to supply equipment and products in conformity therewith.





## AXP14

### Brazed Plate Heat Exchanger

#### General information

Alfa Laval introduced its first brazed plate heat exchanger (BHE) in 1977 and has since continuously developed and optimized its performance and reliability.

Brazing the stainless steel plates together eliminates the need for gaskets and thick frame plates. The brazing material seals and holds the plates together at the contact points ensuring optimal heat transfer efficiency and pressure resistance. The plate design guarantees the longest possible life.

The design options of the brazed heat exchanger are extensive. Different plate patterns are available for various duties and performance specifications. You can choose a standard configuration BHE, or a unit designed according to your own specific needs. The choice is entirely yours.

#### Applications

- Heat pumps
- Commercial
- Refrigeration
- Heat recovery

#### Refrigerant applications

- Gas cooler
- Oil cooler
- Suction gas heater
- Condenser
- Evaporator
- Economizer
- Desuperheater

#### Working principles

The heating surface consists of thin corrugated metal plates stacked on top of each other. Channels are formed between the plates and corner ports are arranged so that the two media flow through alternate channels, usually in counter-current flow for the most efficient heat transfer process.



#### Standard design

The plate pack is covered by cover plates. Connections are located in the front or rear cover plate. To improve the heat transfer design, the channel plates are corrugated.

#### Particulars required for quotation

To enable Alfa Laval's representative to make a specific quotation, specify the following particulars in your enquiry:

- required flow rates or heat load
- temperature program
- physical properties of liquids in question
- desired working pressure
- maximum permitted pressure drop
- operating pressure

#### Examples of connections

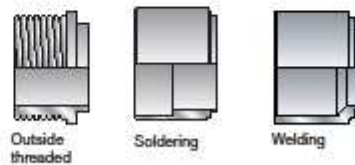

AXP14 - PED approval pressure/temperature graph\*

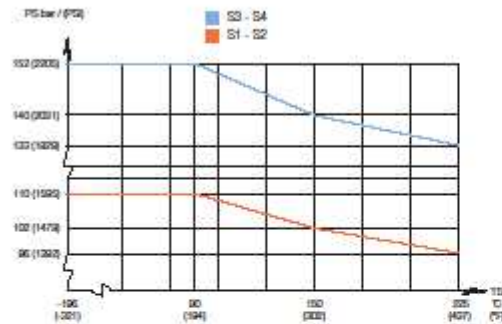

\* For exact values please contact your local Alfa Laval representative.

**Standard dimension and weight\***

A measure mm =  $8 + (n \times 1.1) \pm 1\%$   
 A measure inch =  $0.31 + (n \times 0.043) \pm 1\%$   
 Weight kg\*\* =  $0.323 + (n \times 0.04)$   
 Weight lb\*\* =  $0.712 + (n \times 0.088)$

\*\* excluding connectors  
 (n = number of plates)

**Standard data**

Min. working temperature	-100° C
Max. working temperature	225° C
Min. working pressure	Vacuum
Max. working pressure	see graph
Volume per channel, litres**	0.01
Max particle size, mm	0.4
Max flowrate† m³/h	2.8
Channel port size	14
Min no of plates	10
Max no of plates	150

† Water at 5 m/s (16.4 ft/s) (connection velocity)  
 \*\* CE mark not applicable according to directive 97/23/EC article 3.3

**Standard materials**

Cover plates	Stainless steel
Connections	Stainless steel
Plates	Stainless steel
Brazing material	Copper

**Standard dimensions**

mm (inch)

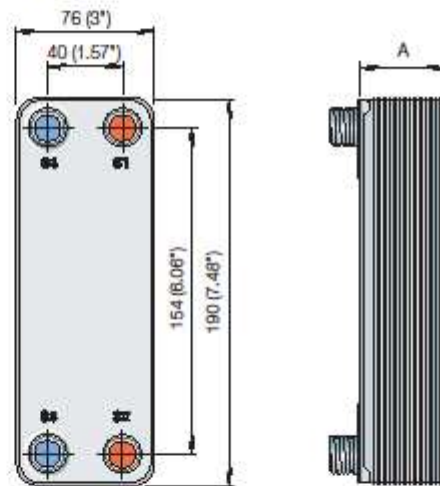

ERC00263EN 0909

Alfa Laval reserves the right to change specifications without prior notification.

**How to contact Alfa Laval**  
 Up-to-date Alfa Laval contact details for all countries are always available on our website at [www.alfalaval.com](http://www.alfalaval.com).

**ANEXO 3: REGULADOR DE PRESIÓN DE 0 A 500 'PSI SWAGELOK KHR**  
**[SWAGELOK, 2013]**



22 Pressure Regulators, K Series

### High-Pressure Piston-Sensing, Hydraulic Pressure-Reducing Regulators (KHR Series)

The KHR series provides control of pressures up to 10 000 psig (689 bar) for both liquid and gas applications. Metal or polymer seats are available.

#### Features

- Self-venting
- Captured vent port in bottom of body
- Panel-mounting configuration available
- Thrust roller bearing eases operation
- High-flow, dual-gauge type filter positively retained in inlet port

#### Technical Data

##### Maximum Inlet Pressure

- 10 000 psig (689 bar)

##### Pressure Control Ranges

- 0 to 500 psig (34.4 bar) through 100 to 10 000 psig (6.8 to 689 bar)

#### Flow Coefficient ( $C_v$ )

- 0.06
  - 0.25 also available
- See page 47 for flow graphs.

#### Supply-Pressure Effect

Flow Coefficient ( $C_v$ )	Pressure Control Range		
	Up to 2500 psig (172 bar)	3600 and 6000 psig (248 and 413 bar)	10 000 psig (689 bar)
0.06	1.0	2.6	4.2
0.25	3.3	8.5	14.6

#### Maximum Operating Temperature

- 212°F (100°C)

#### Weight

- 6.1 lb (2.75 kg)



#### Ports

- 1/4 in. female NPT inlet, outlet, vent, and gauge ports

#### Materials of Construction

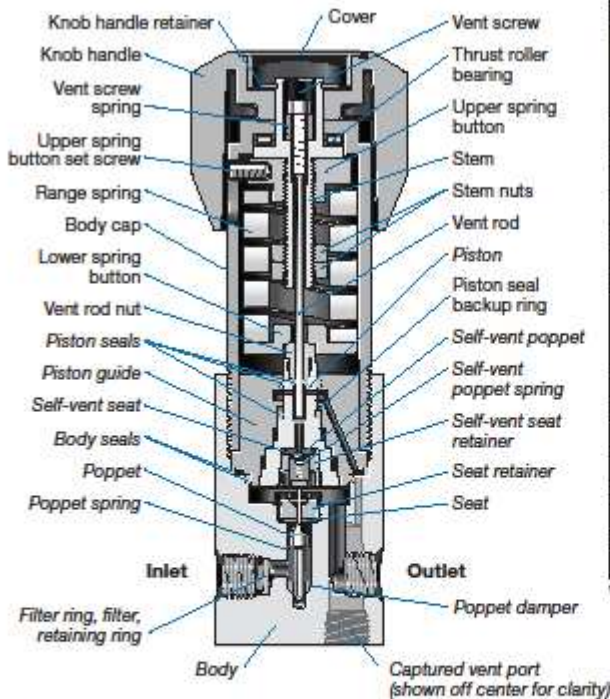

Component	Material
Knob handle, cover	Nylon with 316 SS insert
Spring buttons, upper spring button set screw, knob handle retainer, vent screw, stem nuts, vent rod nut, body cap	316 SS
Vent screw spring	302 SS
Vent rod	431 SS
Stem	CZ114 bronze
Thrust roller bearing	Hardened carbon steel
Range spring	Chrome vanadium steel
Piston seal backup ring	PEEK
Nonwetted lubricant	Hydrocarbon-based
Body, seat retainer, filter, retaining ring, piston, piston guide, self-vent seat retainer	316 SS
Self-vent seat	PEEK
Seat	PEEK or 316 SS
Poppet, self-vent poppet	S17400 SS
Poppet spring	Alloy X-750
Poppet damper, filter ring	PTFE
Self-vent poppet spring	302 SS
Body seals, piston seals	Fluorocarbon FKM
Wetted lubricant	PTFE-based

Wetted components listed in italics.





**Dimensions**

Dimensions, in inches (millimeters), are for reference only and are subject to change.

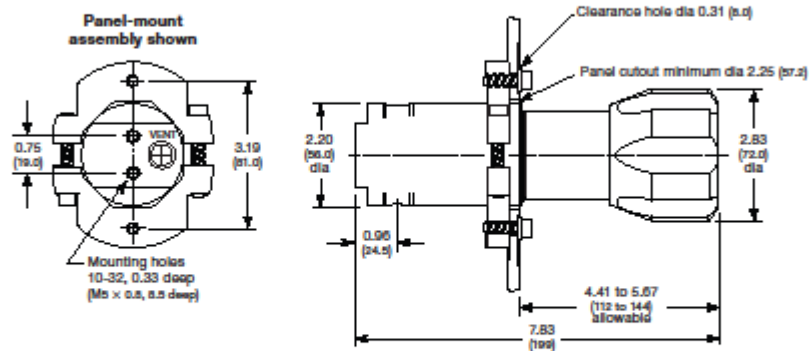

**Ordering Information**

Build a KHR series regulator ordering number by combining the designators in the sequence shown below.

4 5 6 7 8 9 10 11 12 13 14 15 16  
**KHR 1 T X A 4 J 2 U 2 0 0 0 0**

**4 Body Material**

- 1 = 316 SS
- A = 316 SS, ASTM G93 Level E-cleaned

**5 Pressure Control Range**

- J = 0 to 500 psig (0 to 34.4 bar)
- K = 0 to 750 psig (0 to 51.6 bar)
- T = 10 to 1500 psig (0.68 to 103 bar)
- U = 15 to 2500 psig (1.0 to 172 bar)
- V = 25 to 3600 psig (1.7 to 248 bar)
- W = 50 to 6000 psig (3.4 to 413 bar)<sup>Ⓛ</sup>
- X = 100 to 10 000 psig (6.8 to 689 bar)<sup>Ⓛ</sup>

<sup>Ⓛ</sup> Not available for regulators assembled with isolation valves.

**6 Maximum Inlet Pressure**

- X = 10 000 psig (689 bar)

**7 Port Configuration**

- A, B, C, F, M
- See *Port Configurations*, page 52.

**8 Ports**

- 4 = 1/4 in. female NPT

**9 Seat, Seal Material**

- C = PEEK, fluorocarbon FKM
  - J = 316 SS, fluorocarbon FKM<sup>Ⓛ</sup>
- <sup>Ⓛ</sup> Not suitable for gas service.

**10 Flow Coefficient (C<sub>v</sub>)**

- 2 = 0.06
- 6 = 0.25

**11 Sensing Mechanism, Vent**

- U = 316 SS piston, self and captured vent

**12 Handle, Mounting**

- 2 = Knob
- 6 = Knob, panel mount
- For knob handle color options, see page 56.

**13 Isolation Valves**

- 0 = No valves
- For isolation valve options, see page 54.

**14 Cylinder Connections**

- 0 = No connections

**15 Gauges**

- 0 = No gauges
- For inlet and outlet gauge options, see page 54.

**16 Options**

- 0 = No options



**ANEXO 4: COMPRESOR HERMÉTICO ALTERNATIVO PARA  
REFRIGERANTE R-134a DANFOSS SC18GH [DANFOSS, 2011],  
[DANFOSS, 2013]**



**Jorge Jonatan Ohari Vivar Calle**

---

**De:** Martin Cantera [mcantera@rankine.com.pe]  
**Enviado el:** viernes, 07 de junio de 2013 02:23 p.m.  
**Para:** Jorge Jonatan Ohari Vivar Calle  
**Asunto:** RE: Compresor SC18GH

**Importancia:** Alta

Buen día,  
De acuerdo a lo solicitado le cotizo lo siguiente.

COMPRESOR DANFOSS MODELO SC18G 220V R-134A ..... S/.580.00

PRECIO INCLUYE EL IGV.

Saludos

**Martin Cantera O.**  
RANKINE SAC  
[mcantera@rankine.com.pe](mailto:mcantera@rankine.com.pe)  
Av. Angamos 900 Surquillo  
[www.rankine.com.pe](http://www.rankine.com.pe)  
Telf. 4466000 - 4476640  
Nextel 998118713

---

**De:** Jorge Jonatan Ohari Vivar Calle [mailto:JVivarC@alicorp.com.pe]  
**Enviado el:** viernes, 07 de junio de 2013 11:38 a.m.  
**Para:** mcantera@rankine.com.pe  
**Asunto:** Compresor SC18GH

Estimado Martin

De acuerdo a lo conversado por teléfono, por favor quisiera cotizar un compresor modelo SC18GH marca DANFOSS, con las siguientes condiciones de trabajo.

Fluido: R-134a  
Presión de entrada: 4,5 bar  
Temperatura de evaporación: 13,5°C  
Presión de salida: 17 bar  
Temperatura de condensación: 60°C  
Caudal: 0,015 kg/s

Por favor confirmar la recepción del correo.

Saludos

## Compresores herméticos alternativos para instalaciones domésticas y pequeñas instalaciones comerciales

### Compresores herméticos para refrigerante R-134a

Aplicación	Códigos			Capacidad [W] en las condiciones indicadas													Consumo de potencia [W]					
	Compresor	Compresor en paquete	Compresor (pack individual, con anillos refrigerantes)	Compresor con acalla refrigerante	Temperatura de evaporación [°C]													Temperatura de evaporación [°C]				
					-45	-40	-35	-30	-25	-20	-15	-10	-5	0	5	10	15	20	-35	-25	-10	5
H. DOMESTICO	PL35G	101G0250	195B0245					28	39	53	69	89	112	140	172	209			48	60	84	113
	TL2.5G	102G4251	195B0268			11	22	36	51	69	90	116	145	179	219	264			66	96	133	
	TL3G	102G4350	195B0006				25	41	59	81	106	136	170	211	258	312			83	118	154	
	TL4G	102G4452	195B0008				41	58	80	107	140	180	226	280	342	413			100	149	205	
	TL5G	102G4550	195B0011				56	79	107	139	178	224	278	341	414	497			109	172	241	
	FR6G	103G6660	195B0191				48	83	124	171	226	290	365	452	552			126	194	272		
	FR7.5G	103G6680	195B0024	103G6690			62	99	142	193	254	325	408	505	618			151	231	321		
	FR8.5G	103G6780	195B0026	103G6700			85	123	171	228	298	381	478	592	722			179	265	362		
	FR10G	103G6880	195B0027	103G6800			92	136	188	250	324	412	516	638	779			202	317	445		
	FR11G	103G6980	195B0028				115	170	233	307	395	501	628	780			93	181	290	383		
	SC10G	104G8000	195B0043				23	60	113	183	268	369	486	618	764	925	1100		148	227	355	493
	SC12G	104G8240	195B0050	104G8250			65	113	175	252	348	464	603	768	960	1182	1437		233	340	505	695
	SC15G	104G8520	195B0053	104G8530				164	290	424	568	728	908	1110	1340	1600		331	507	695		
	SC18G	104G8820	195B0059	104G8830				283	394	526	684	870	1087	1337	1624	1950		382	575	780		
	SC21G	104G8140	195B0048					333	453	606	792	1012	1268	1560	1889	2256		465	879	1190		
	SC12/12G	104G8280	195B0051				129	226	350	505	696	928	1206	1535	1920	2364	2875		662	1014	1390	
	SC15/15G	104G8580	195B0056					328	581	847	1137	1457	1815	2220	2679	3201		771	1156	1581		
	SC18/18G	104G8880	195B0060					566	788	1052	1368	1740	2174	2674	3248	3900		84				
	SC21/21G	104G8180	195B0049					667	907	1212	1584	2025	2536	3120	3778	4511						
	LAP	PL50F	101G0222	195B0001					40	56	74	95	120	148					58	84		
		TL3FT	102G4324	195B0484				21	34	50	69	92	120						45	62	92	
		TL54FT	102G4424	195B0463				27	43	63	88	117	152						68	97	123	
		TL55FT	102G4524	195B0321				48	71	98	131	170	216						84.5	114	165	
TLES5.7FT.3		102G4615					66	90	120	156	200	253						90	120	170		
TLES6.5FT.3		102G4703	on request				72	100	134	176	228	290						107	142	200		
NL6FT		105G6628	195B0296				60	84	115	152	198	253						93	123	184		
NL6.1FT		105G6620	195B0440				60	84	115	152	198	253						93	123	184		
NL7.3FT		105G6726	195B0441	105G6731			71	100	136	181	235	299						108	145	220		
NL8.4FT		105G6865	195B0442	105G6866			87	120	162	213	275	350						127	169	252		
NL10FT		105G6829	195B0327	105G6839			113	158	213	281	361	455						159	217	327		
SC12FT		104G8205	195B0282 (D)	104G8215			103	163	233	314	408	517	645					184	265	380		
SC15FT		104G8505	195B0407				126	197	280	376	489	620	772					223	311	451		
SC18FTX		104G8805	195B0408				144	229	325	437	567	719	896					257	365	517		
SC21FTX		104G8105	195B0514				192	296	415	533	713	901	1119					296	428	613		
TL4FX		102G4400	195B0007				31	44	61	81	107	137						60	81	122		
TL5FX		102G4501	195B0241				43	60	82	110	144	183						70	101	154		
TL55FX		102G4520	195B0010				48	71	98	131	170	216						82	112	162		
TL56FX		102G4620	195B0235				58	77	104	139	183	235						84	119	181		
TL57FX		102G4720	195B0255				66	89	120	160	208	264						97	136	207		
NL7FX		105G6706	195B0176				71	99	136	182	238	303						71	106	303		
NL9FX		105G6802	195B0178				74	111	155	207	268	340						109	167	260		
NL11FX		105G6900	195B0182				102	146	200	268	351	453						137	212	331		
SC15FX	104G8500	195B0052				100	155	230	325	439	573	726					186	275	432			
SC18FX	104G8800	195B0057				129	194	280	388	518	669	842					206	313	492			
SC21FX	104G8100	195B0047				186	246	335	454	602	780	987					275	380	600			
MBP	NL6.1MF	105G6660	195B0411				141	189	245	312	390	482	588	709				187	243			
	NL7.3MF	105G6772	195B0370				179	236	304	385	480	591	719	867				227	298			
	NL8.4MF	105G6879	195B0371				213	277	353	445	553	679	825	994				261	349			
	NL10MF	105G6885	195B0276	105G6887			266	346	441	554	687	843	1023	1231				323	435			
	NL11MF	105G6151	195B0432				292	380	485	609	756	927	1125	1354				360	495			
	NL10MF	105G6888	195B0566				88	137	194	262	343	440	554	688	845			134	198	308	426	
	SC18MF	104G8804	on request					430	563	722	912	1137	1400					507	657			
	SC21MF	104G8120	195B0478					530	682	866	1085	1343	1645	1996				594	794			
	GS26MF	10780700	195B0433					754	989	1266	1591	1970	2411					696	942			
	GS34MF	10780701	195B0435					998	1296	1648	2063	2550	3115					900	1234			
MBP	TL6GH	102G4455	195B0122					104	140	182	230	287	353	429				121	159			
	FR7GH	103G6683	195B0167	103G6692				199	255	327	417	525	655	807				192	258			
	SC10GH	104G8041	195B0142					233	352	478	613	762	927	1113	1323			281	395			
	SC10GHH		on request	104G8071				259	352	467	604	762	942	1144				260	345			
	SC12GH	104G8261	195B0249					429	577	752	957	1196	1471	1787				356	487			
	SC15GH	104G8561	195B0144					559	723	915	1139	1398	1698	2041				424	565			
	SC15GHH		195B0055	104G8571				435	570	726	911	1135	1405	1731				377	505			
SC18GH	104G8860	195B0246					539	676	855	1077	1340	1645	1990				498	697				
SC18GH	104G8861	195B0246					485	639	825	1047	1310	1618	1976	2389				452	605			
GS26GHX	10780702	195B0434					937	1198	1510	1880	2316	2826	3417	4098				737	970			

\*) Para el compresor TLES5.7FT.3 (pack individual): (D) = Enfriador de aceite  
 195B0421 (LST) si no se requiere un conector adicional (para el condensador de marcha); (LST) = Bajo par de arranque  
 195B0562 (LST) si se requiere un conector adicional (para el



Desplazamiento [cm <sup>3</sup> ]	Refrigeración del compresor recomendada a determinadas temperaturas ambiente									Tensión y frecuencias	Equipos eléctricos					Compresor	Dimensiones								
	32 °C			38 °C			43 °C				LST (RSIR)		HST (CSIR)		HST (CSR)		LST/HST		Altura (mm)		Ubicación de los conectores (ID) (mm)				
	LSP	MSP	HSP	LSP	MSP	HSP	LSP	MSP	HSP		Dispositivo de arranque PTC		Relé de arranque		Dispositivo de arranque		Anclaje de cables		A		B	C	D	E	F
	Terminales		Terminales		Terminales	Terminales		Terminales			Terminales	Anclaje de cables	Tapa	A	B		C	D	E	F					
2.00		F <sub>2</sub>	F <sub>1</sub>		F <sub>2</sub>	F <sub>1</sub>				1/5	103N0011	103N0018	117U6021	117U5014		103N1010	103N0491	PL35G	137	135	6.2	6.2	5.0		
2.61	S	S	S	S	S	S	S	S	F <sub>2</sub>	1/2/3/4	103N0011	103N0018	117U6007	117U5014		103N1010	103N0011	TL2.5G	163	159	6.2	6.2	5.0		
3.13	S	-	F <sub>2</sub>	S	S	F <sub>2</sub>	S	S	F <sub>2</sub>	1/2/3	103N0011	103N0018	117U6009	117U5014		103N1010	103N0010	TL3G	163	159	6.2	6.2	5.0		
3.86	S	-	F <sub>2</sub>	S	S	F <sub>2</sub>	S	S	F <sub>2</sub>	1/2/3	103N0011	103N0018	117U6004	117U5014		103N1010	103N0010	TL4G	173	169	6.2	6.2	5.0		
5.08	S	S	F <sub>2</sub>	S	S	F <sub>2</sub>	S	S	F <sub>2</sub>	1/2/3	103N0011	103N0018	117U6000	117U5014		103N1010	103N0010	TL5G	173	169	6.2	6.2	5.0		
6.23	S	S	F <sub>2</sub>	S	S	F <sub>2</sub>	S	S	F <sub>2</sub>	1/2/3	103N0011	103N0018	117U6000	117U5015		103N1010	103N0010	FR6G	196	191	8.2	6.2	6.2		
6.93	S	F <sub>2</sub>	F <sub>1</sub>	S	F <sub>2</sub>	F <sub>1</sub>	O/F <sub>1</sub>	F <sub>2</sub>	F <sub>2</sub>	1/2/3	103N0011	103N0018	117U6011	117U5015		103N1010	103N0010	FR7.5G	196	191	8.2	6.2	6.2	6.2	
7.95	S	F <sub>2</sub>	F <sub>1</sub>	O/F <sub>1</sub>	F <sub>2</sub>	F <sub>1</sub>	O/F <sub>1</sub>	F <sub>2</sub>	F <sub>2</sub>	1/2/3	103N0011	103N0018	117U6015	117U5015		103N1010	103N0010	FR8.5G	196	191	8.2	6.2	6.2	6.2	
9.05	S	F <sub>2</sub>	F <sub>1</sub>	O/F <sub>1</sub>	F <sub>2</sub>	F <sub>1</sub>	O/F <sub>1</sub>	F <sub>2</sub>	F <sub>2</sub>	1/2/3	103N0011	103N0018	117U6010	117U5015		103N1010	103N0010	FR9G	196	191	8.2	6.2	6.2	6.2	
11.15	F <sub>2</sub>	F <sub>1</sub>	F <sub>2</sub>	F <sub>1</sub>	F <sub>2</sub>	F <sub>1</sub>	F <sub>2</sub>	F <sub>1</sub>	F <sub>2</sub>	1/2	103N0011	103N0018	117U6010	117U5015		103N1010	103N0010	FR11G	196	191	8.2	6.2	6.2	6.2	
10.29	F <sub>1</sub>	F <sub>1</sub>	F <sub>1</sub>	F <sub>1</sub>	F <sub>1</sub>	F <sub>1</sub>	F <sub>1</sub>	F <sub>1</sub>	F <sub>1</sub>	1/2/3	103N0002		117U6002	117U5017		103N1004	103N0009	SC10G	199	193	8.2	6.2	6.2		
12.87	O/F <sub>1</sub>	F <sub>2</sub>	F <sub>1</sub>	O/F <sub>1</sub>	F <sub>2</sub>	F <sub>1</sub>	O/F <sub>1</sub>	F <sub>2</sub>	F <sub>2</sub>	1/2/3	103N0002		117U6005	117U5017		103N1004	103N0009	SC12G	209	203	10.2	6.2	6.2	6.2	
15.38	O/F <sub>1</sub>	F <sub>2</sub>	F <sub>1</sub>	O/F <sub>1</sub>	F <sub>2</sub>	F <sub>1</sub>	O/F <sub>1</sub>	F <sub>2</sub>	F <sub>2</sub>	1/2/3	103N0002		117U6005	117U5017		103N1004	103N0009	SC15G	209	203	10.2	6.2	6.2	6.2	
17.69	O/F <sub>1</sub>	F <sub>2</sub>	F <sub>1</sub>	O/F <sub>1</sub>	F <sub>2</sub>	F <sub>1</sub>	O/F <sub>1</sub>	F <sub>2</sub>	F <sub>2</sub>	2/5			117U6019	117U5017		103N1004	103N0009	SC18G	219	213	10.2	6.2	6.2	6.2	
20.95	F <sub>2</sub>	F <sub>2</sub>	F <sub>2</sub>	F <sub>2</sub>	F <sub>2</sub>	F <sub>2</sub>	F <sub>2</sub>	F <sub>2</sub>	F <sub>2</sub>	1/2/3					117-7028	103N1004	103N0009	SC21G	219	213	10.2	6.2	6.2		
2x12.87	F <sub>2</sub>	F <sub>2</sub>	F <sub>2</sub>	F <sub>2</sub>	F <sub>2</sub>	F <sub>2</sub>	F <sub>2</sub>	F <sub>2</sub>	F <sub>2</sub>	1			117U6003	117U5017		103N1004	103N0009	SC12/12G	249	244	12	6.2	6.2		
2x15.38	F <sub>2</sub>	F <sub>2</sub>	F <sub>2</sub>	F <sub>2</sub>	F <sub>2</sub>	F <sub>2</sub>	F <sub>2</sub>	F <sub>2</sub>	F <sub>2</sub>	1			117U6005	117U5017		103N1004	103N0009	SC15/15G	249	244	12	6.2	6.2		
2x17.69	F <sub>2</sub>	F <sub>2</sub>	F <sub>2</sub>	F <sub>2</sub>	F <sub>2</sub>	F <sub>2</sub>	F <sub>2</sub>	F <sub>2</sub>	F <sub>2</sub>	1			117U6019	117U5017		103N1004	103N0009	SC18/18G	259	254	16	6.2	6.2		
2x20.95	F <sub>2</sub>	F <sub>2</sub>	F <sub>2</sub>	F <sub>2</sub>	F <sub>2</sub>	F <sub>2</sub>	F <sub>2</sub>	F <sub>2</sub>	F <sub>2</sub>	1					117-7028	103N1004	103N0009	SC21/21G	259	254	16	6.2	6.2		
2.50		F <sub>2</sub>			F <sub>2</sub>					1			117U6021	117U5014		103N1010	103N0491	PL50F	137	135	6.2	6.2	5.0		
3.13	S			S			S			2	103N0011	103N0018	117U6007	117U5014		103N1010	103N0010	TL3.5FT	173	169	6.2	6.2	5.0		
3.86	S			S			S			2	103N0011	103N0018	117U6004	117U5014		103N1010	103N0010	TL4.5FT	173	169	6.2	6.2	5.0		
5.08	S			S			S			2	103N0011	103N0018	117U6000	117U5014		103N1010	103N0010	TL5.5FT	173	169	6.2	6.2	5.0		
5.70	S			S			S			2	103N0011	103N0018	117U6004	117U5014		103N1010	103N0010	TL5.5.7FT.3	173	169	6.2	6.2	5.0		
6.49	S			S			S			2	103N0011	103N0018	117U6016	117U5014		103N1010	103N0011	TL5.6.5FT.3	173	169	6.2	6.2	5.0		
6.13	S			S			S		2/5				117U6000	117U5015		103N1010	103N0010	NL6FT	197	191	8.2	6.2	5.0		
6.13	S			S			S		2				117U6000	117U5015		103N1010	103N0010	NL6.1FT	188	182	6.2	6.2	5.0		
7.27	S			S			O/F <sub>1</sub>			2	103N0011	103N0018	117U6001	117U5015		103N1010	103N0010	NL7.3FT	188	182	6.2	6.2	5.0	5.0	
8.35	S			O/F <sub>1</sub>			O/F <sub>1</sub>			2	103N0011	103N0018	117U6001	117U5015		103N1010	103N0010	NL8.4FT	190	184	6.2	6.2	5.0	5.0	
10.10	S			O/F <sub>1</sub>			O/F <sub>1</sub>			2	103N0011	103N0018	117U6002	117U5015		103N1010	103N0010	NL10FT	203	197	8.2	6.2	6.2	6.2	
12.87	O/F <sub>1</sub>			O/F <sub>1</sub>			F <sub>2</sub>			2/5	103N0002		117U6003	117U5017		103N1004	103N0009	SC12FT	209	203	8.2	6.2	6.2	6.2	
15.38	F <sub>1</sub>			O/F <sub>1</sub>			F <sub>2</sub>			2/5	103N0002		117U6005	117U5017		103N1004	103N0009	SC15FT	209	203	10.2	6.2	6.2		
17.69	F <sub>1</sub>			F <sub>2</sub>			F <sub>2</sub>			2/5			117U6019	117U5017		103N1004	103N0009	SC18FTX	219	213	10.2	6.2	6.2		
20.95	F <sub>1</sub>			F <sub>2</sub>			F <sub>2</sub>			2			117U6019	117U5017		103N1004	103N0009	SC21FTX	219	213	10.2	6.2	6.2		
3.06	S			S						1	103N0011	103N0018	117U6009	117U5014		103N1010	103N0010	TL4FX							
3.86	S			S						1	103N0011	103N0018	117U6004	117U5014		103N1010	103N0010	TL5FX							
5.08	S			S						1	103N0011	103N0018	117U6004	117U5014		103N1010	103N0010	TL5.5FX							
5.70	S			S						1	103N0011	103N0018	117U6004	117U5014		103N1010	103N0010	TL5.6FX							
6.49	S			S*						1	103N0011	103N0018	117U6000	117U5014		103N0016	103N1010	TL5.7FX							
7.27	S			S						1	103N0011	103N0018	117U6000	117U5015		103N1010	103N0010	NL7FX							
8.35	S			S						1	103N0011	103N0018	117U6001	117U5015		103N1010	103N0010	NL9FX							
11.15	O/F <sub>1</sub>									1	103N0011	103N0018	117U6002	117U5015		103N1010	103N0010	NL11FX							
15.38	O/F <sub>1</sub>			O/F <sub>1</sub>						1	103N0002		117U6003	117U5017		103N1004	103N0009	SC15FX							
17.69	O/F <sub>1</sub>			O/F <sub>1</sub>						1			117U6005	117U5017		103N1004	103N0009	SC18FX							
20.95	O/F <sub>1</sub>			O/F <sub>1</sub>						1			117U6019	117U5017		103N1004	103N0009	SC21FX							
6.13		F <sub>1</sub>	F <sub>1</sub>		F <sub>1</sub>	F <sub>1</sub>		F <sub>1</sub>	F <sub>1</sub>	2/5	103N0011	103N0018	117U6015	117U5015		103N1010	103N0011	NL6.1MF	190	184	8.2	6.2	6.2		
7.27		F <sub>1</sub>	F <sub>1</sub>		F <sub>1</sub>	F <sub>1</sub>		F <sub>1</sub>	F <sub>1</sub>	2/5	103N0011	103N0018	117U6016	117U5015		103N1010	103N0011	NL7.3MF	197	191	8.2	6.2	6.2		
8.35		F <sub>1</sub>	F <sub>1</sub>		F <sub>1</sub>	F <sub>1</sub>		F <sub>1</sub>	F <sub>1</sub>	2/5	103N0011	103N0018	117U6016	117U5015		103N1010	103N0011	NL8.4MF	197	191	8.2	6.2	6.2		
10.10		F <sub>1</sub>	F <sub>1</sub>		F <sub>1</sub>	F <sub>1</sub>		F <sub>1</sub>	F <sub>1</sub>	2/5	103N0011	103N0018	117U6022												



# SC18GH Heat Pump Compressor R134a 220-240V 50/60Hz

**General**

Code number	104G8861
Approvals	EN 60335-2-34, UL984
Compressors on pallet	80

**Application**

Application	HBP	
Frequency	Hz	50      60
Evaporating temperature	°C	-15 to 20    -15 to 15
Voltage range	V	198 - 254    198 - 254
Max. condensing temperature continuous (short)	°C	70 (70)      60 (70)
Max. winding temperature continuous (short)	°C	125 (135)    125 (135)

**Cooling requirements**

Frequency	Hz	50		60			
Application		LBP	MBP	HBP	LBP	MBP	HBP
32°C		-	-	F <sub>2</sub>	-	-	F <sub>2</sub>
38°C		-	-	F <sub>2</sub>	-	-	F <sub>2</sub>
43°C		-	-	F <sub>2</sub>	-	-	F <sub>2</sub>

Remarks on application:

**Motor**

Motor type	CSR	
LRA (rated after 4 sec. UL984), HST   LST	A	21.8      -
Cut In Current, HST   LST	A	21.8      -
Resistance, main   start winding (25°C)	Ω	3.5        12.1

**Design**

Displacement	cm <sup>3</sup>	17.69
Oil quantity (type)	cm <sup>3</sup>	500 (polyolester)
Maximum refrigerant charge	g	1300
Free gas volume in compressor	cm <sup>3</sup>	1460
Weight without electrical equipment	kg	13.7

**Dimensions**

Height	mm	A	219
		B	213
		B1	193
		B2	110
Suction connector	location/I.D. mm   angle	C	10.2   37°
	material   comment		Cu-plated steel   Al cap
Process connector	location/I.D. mm   angle	D	6.2   37°
	material   comment		Cu-plated steel   Al cap
Discharge connector	location/I.D. mm   angle	E	8.2   37°
	material   comment		Cu-plated steel   Al cap
Oil cooler connector	location/I.D. mm   angle	F	-
	material   comment		-
Connector tolerance	I.D. mm		±0.09
Remarks:			

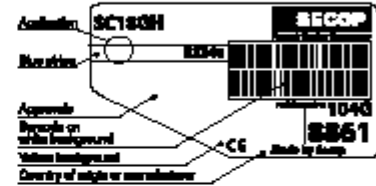

- S - Static cooling normally sufficient
- O - Oil cooling
- F<sub>1</sub> - Fan cooling 1.5 m/s (compressor compartment temperature equal to ambient temperature)
- F<sub>2</sub> - Fan cooling 3.0 m/s necessary
- SG - Suction gas cooling normally sufficient
- - not applicable in this area

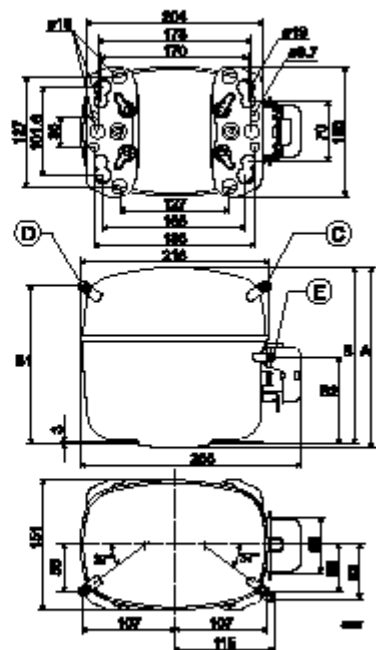

**ANEXO 5: REGULADOR DE PRESIÓN DE 0 A 100 'PSI SWAGELOK KLF  
[SWAGELOK, 2013]**



10 Pressure Regulators, K Series

**High-Sensitivity Diaphragm-Sensing,  
Pressure-Reducing Regulators (KLF Series)**

The KLF series provides high-sensitivity pressure control of gases or liquids with minimum droop in both low-flow and low-pressure applications.

**Features**

- Large-diameter convoluted, nonperforated diaphragm for increased pressure sensitivity
- Metal-to-metal diaphragm seal
- High-flow, dual-gauze type filter positively retained in inlet port

**Technical Data**

**Maximum Inlet Pressure**

- 3600 psig (248 bar)

**Pressure Control Ranges**

- 0 to 2.0 psig (0.13 bar) through 0 to 250 psig (17.2 bar)

**Flow Coefficient (C<sub>v</sub>)**

- 0.02 and 0.06

See page 43 for flow graphs.

- 0.20 and 0.50 also available

**Supply-Pressure Effect**

Flow Coefficient (C <sub>v</sub> )	Pressure Control Range	
	Up to 10 psig (0.68 bar)	25 psig (1.7 bar) and Higher
0.02	0.1	0.2
0.06	0.4	0.6
0.20	0.7	0.9
0.50	1.0	1.4

**Maximum Operating Temperature**

- 176°F (80°C) with PCTFE seat
- 392°F (200°C) with PEEK seat

**Weight**

- 4.0 lb (1.8 kg)

**Ports**

- 1/4 in. female NPT inlet, outlet, and gauge ports



**Materials of Construction**

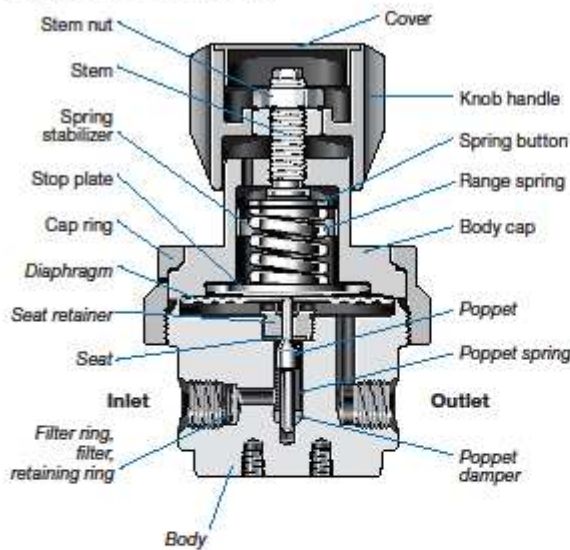

Component	Material
Knob handle, cover	Nylon with 316 SS insert
Spring button	Zinc-plated steel
Spring stabilizer <sup>①</sup>	301 SS
Range spring	316 SS or zinc-plated steel, depending on configuration
Stem, stem nut, cap ring, stop plate, body cap, panel nuts <sup>②</sup>	316 SS
Nonwetted lubricant	Hydrocarbon-based
Body, seat retainer, filter, retaining ring	316 SS
Seat	PCTFE or PEEK
Diaphragm, <sup>③</sup> poppet spring	Alloy X-750
Poppet	S17400 SS
Poppet damper, filter ring	PTFE
Wetted lubricant	PTFE-based

Wetted components listed in italics.

① Not required in all configurations.

② Not shown.

③ Regulators with control range 0 to 250 psig (0 to 17.2 bar) are assembled with two diaphragms.





**Dimensions**

Dimensions, in inches (millimeters), are for reference only and are subject to change.

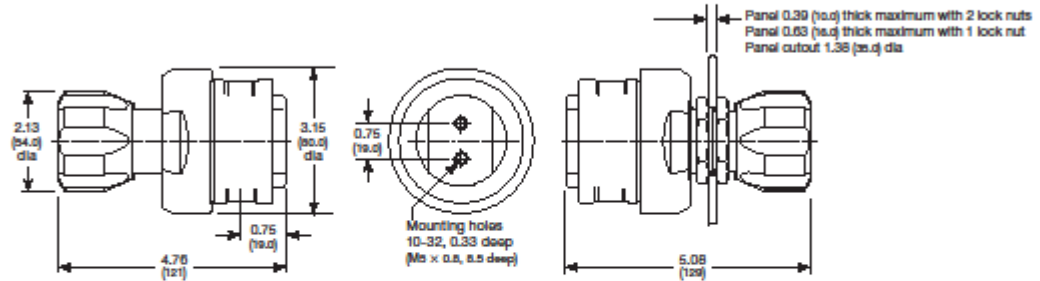

**Ordering Information**

Build a KLF series regulator ordering number by combining the designators in the sequence shown below.



**4 Body Material**

- 1 = 316 SS
- A = 316 SS, ASTM G93 Level E-cleaned

**5 Pressure Control Range**

- B = 0 to 2.0 psig (0 to 0.13 bar)<sup>①</sup>
- C = 0 to 10 psig (0 to 0.68 bar)
- D = 0 to 25 psig (0 to 1.7 bar)
- E = 0 to 50 psig (0 to 3.4 bar)
- F = 0 to 100 psig (0 to 6.8 bar)
- G = 0 to 250 psig (0 to 17.2 bar)

<sup>①</sup> Available with 15 psig (1.0 bar) maximum inlet pressure only.

**6 Maximum Inlet Pressure<sup>②</sup>**

- C = 15 psig (1.0 bar)<sup>②</sup>
- F = 100 psig (6.8 bar)
- J = 500 psig (34.4 bar)
- L = 1000 psig (68.9 bar)
- P = 3000 psig (206 bar)<sup>②</sup>
- R = 3600 psig (248 bar)<sup>②</sup>

<sup>①</sup> For better resolution and control, select a pressure that closely matches system pressure.

<sup>②</sup> Available with 0 to 2.0 psig (0 to 0.13 bar) pressure control range only.

<sup>③</sup> Available for regulators assembled with CGA cylinder connection or inlet hose only.

<sup>④</sup> Not available for regulators assembled with CGA cylinder connection or inlet hose.

**7 Port Configuration**

- A, B, C, E, F, H, K, L, M, N
- See *Port Configurations*, page 52.

**8 Ports**

- 4 = 1/4 in. female NPT

**9 Seat Material**

- 1 = PCTFE
- 2 = PEEK

**10 Flow Coefficient (C<sub>v</sub>)**

- 1 = 0.02
- 2 = 0.06
- 5 = 0.20
- 7 = 0.50

**11 Sensing Mechanism, Vent**

- A = Alloy X-750 diaphragm, no vent
- E = Alloy X-750 diaphragm, captured vent, no self vent

**12 Handle, Mounting**

- 2 = Knob
- 3 = 316 SS antitamper nut
- 6 = Knob, panel mount
- 7 = 316 SS antitamper nut, panel mount

For knob handle color options, see page 56.

**13 Isolation and Relief Valves**

- 0 = No valves
- For isolation and relief valve options, see page 54.

**14 Cylinder Connections**

- 0 = No connection
- For CGA cylinder connection options, see page 53.

**15 Gauges**

- 0 = No gauges
- For inlet and outlet gauge options, see page 54.

**16 Options**

- 0 = No options
- 3 = 3 ft, 1/4 in. FM series metal flexible hose, 1/4 in. female NPT inlet<sup>①</sup>
- 4 = 3 ft, 1/4 in. TH series PTFE-lined, stainless steel braided hose, 1/4 in. female NPT inlet<sup>①</sup>

For more information about hoses, see page 56.

<sup>①</sup> Hoses are not available for ASTM G93 Level E-cleaned regulators.



**ANEXO 6: BOMBA CENTRÍFUGA HIDROSTAL 32-125[HIDROSTAL, 2012]**

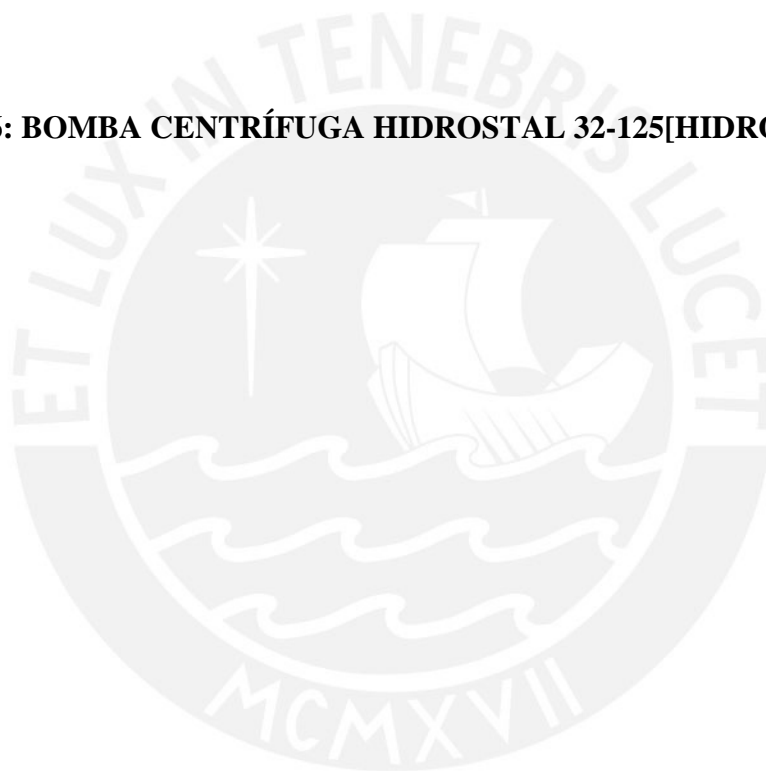

Tel: (51 - 1) 319 - 1000  
Fax: (51 - 1) 319 - 1019  
mgalarza@hidrostral.com.pe



SEÑORES: <b>ALICORP</b>	MENSAJE: COTIZACION MGB 200-590
ATENCIÓN: <b>ING. JORGE VIVAR</b>	PAGINA: 1/2
FECHA: 09 de setiembre de 2013	

Estimados Señores:

Atendiendo su solicitud de cotización de la referencia y de acuerdo a lo proporcionado por ustedes nos es grato cotizarles lo siguiente:

**ITEM 01: DESCRIPCIÓN GENERAL**

Bomba centrífuga horizontal marca **HIDROSTAL** fabricada en el Perú, según norma ISO/DIS 2858. Caja de bomba con succión axial y descarga radial e impulsor cerrado. Soporte construido en fierro fundido con rodamientos lubricados por grasa. Base común de acero estructural para montaje bomba-motor y sistema de transmisión mediante acoplamiento marca Guardex, con su respectivo guardacople.  
Motor eléctrico asíncrono trifásico marca **WEG** construido según standard IEC, aislamiento clase F, grado de protección IP55, totalmente cerrado, forma constructiva B3D Horizontal, para operar en instalaciones trifásicas de 60 Hz. y para arranque directo o estrella triángulo. Para temperatura ambiente de hasta 40°C y operación hasta 1000 m.s.n.m.

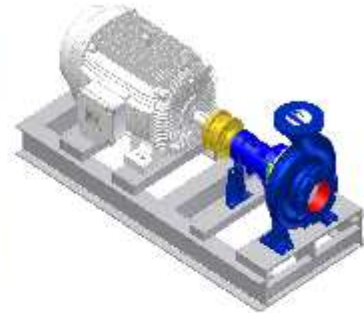

<b>Modelo</b>	<b>EQ. 32-125-0HE-B385-AC/1R-TG1030-0.75-18/137</b>			
<b>Datos de Bomba</b>				
Líquido a bombear	: Agua	<b>Materiales de Construcción</b>		
Caudal (LPS)	: <b>1.5 LPS</b>	Ejecución		
A.D.T. (m)	: <b>8.3</b>	Caja		
Eficiencia (%)	: 50%	Impulsor		
Potencia Abs. (hp)	: 0.34	Eje		
Máx Pot. Abs. (hp)	: 0.58	<b>Datos de Motor</b>		
NPSH req. (m)	: 1.8	Potencia (hp)	: <b>0.75</b>	
Ø de impulsor(mm)	: 137 @ 1710 rpm	Velocidad (rpm)	: 1710	
<b>Características de Bomba</b>			Frame	: 71
Sellado	: Mecánico	Voltaje (v)	: 220/380/440	
Ø Succión (mm)	: 50	F. S.	: 1.15	
Ø Descarga(mm)	: 32	Nº de polos	: 4	
		Fases	: 3	

<b>PRECIOS</b>					
Item	Cant.	Descripción	V. Vta. Unit S /	Octo %	V. Vta. Neta S /
01	01	EQ. 32-125-0HE-B385-AC/1R-TG1030-0.75-18/137	5,505.00	20	4,404.00
<b>VALOR VENTA NETA TOTAL</b>			S /		<b>4,404.00</b>
<b>I.G.V. 18%</b>			S /		<b>792.72</b>
<b>PRECIO VENTA TOTAL</b>			S /		<b>5,196.72</b>

Precios: En Nuevos Soles.

**CONDICIONES DE VENTA**

**Condición Nº 1:** Al recibir su orden de compra, por ser productos sujetos a especificaciones técnicas para poder cumplir con la calidad ofrecida, es necesario aclarar todos los detalles antes de iniciar la fabricación y/o el despacho.

**Condición Nº 2:** De haberse además convenido un pago inicial es necesario que este se haya realizado. Luego de cumplido con ello emitiremos nuestro Acuse Confirmación de Pedido y/o Factura.

**Forma de Pago:** FACTURA A 60 DIAS

**Plazo de entrega:** DE 2 SEMANAS

**Embalaje:** Los productos se entregarán sin embalar, salvo que haya sido ofrecido expresamente en nuestra oferta.



CURVAS DE OPERACION A 60 Hz

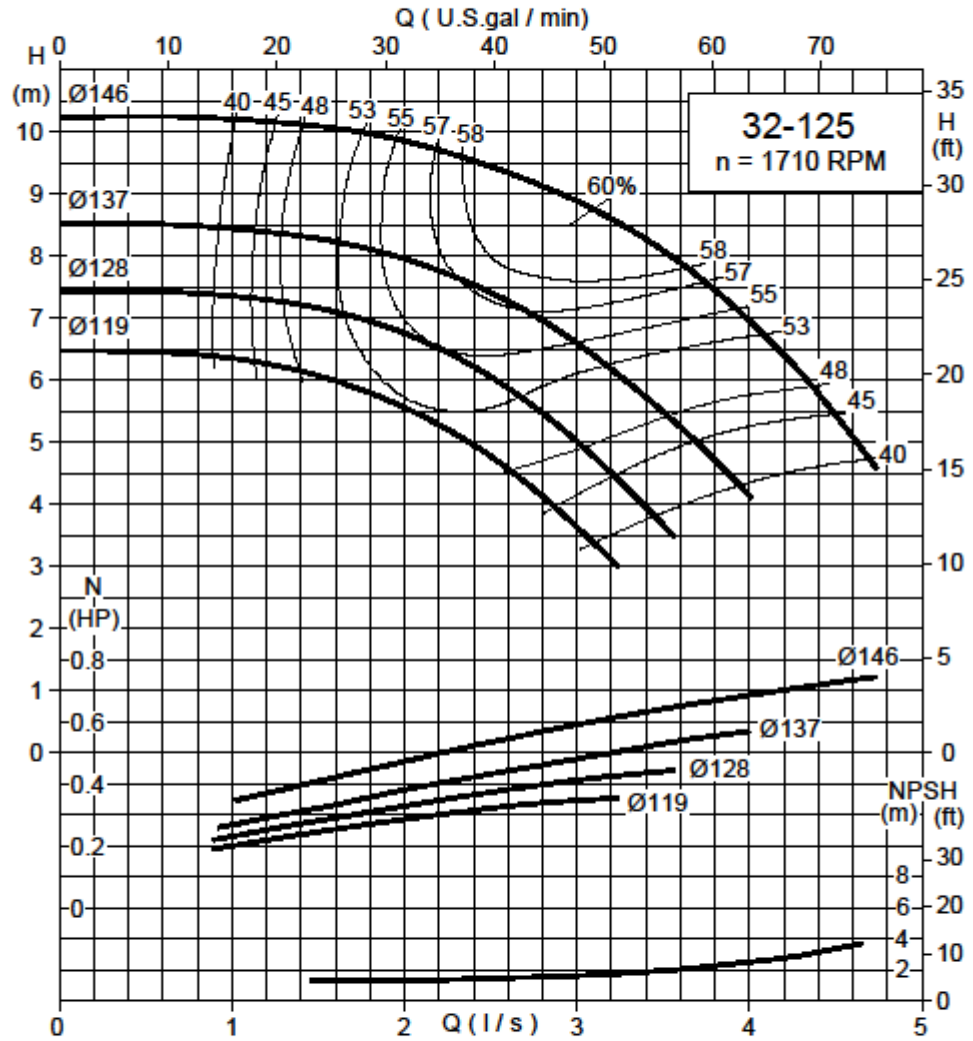

CURVAS MOSTRADAS PARA BOMBAS CON CAJA EN FIERRO FUNDIDO GRIS O NODULAR CON RECUBRIMIENTO CERAMICO.  
CURVAS EN CONDICIONES NORMALES DE OPERACION (AGUA LIMPIA A 20°C) DE ACUERDO A NORMA ISO 9906:1999 GRADO 2.

\*Todas las especificaciones son las vigentes al momento de la emisión de las mismas. Como nuestro objetivo es "La mejora continua", entregaremos el producto especificado o mejorado.

BOMBA CENTRIFUGA  
ISO 9906:1999  
CATALOGO I

HIDROSTAT S.A.  
PORTADA DEL SOL 722 - LIMA 36, PERU  
APARTADO POSTAL 3969 - LIMA 1, PERU  
E-MAIL: hidrostat@hidrostat.com.pe  
WEB: www.hidrostat.com.pe

VERSION: B  
TELEFONO: (01-1) 319 10 00  
FAX: (01-1) 489 00 06  
FAX VENTAS: (01-1) 319 10 19  
SERVICIO AL CLIENTE SOLO PERU: 0801-10000







TABLA DE MEDIDAS - COPLES GUARDEX TIPO TG

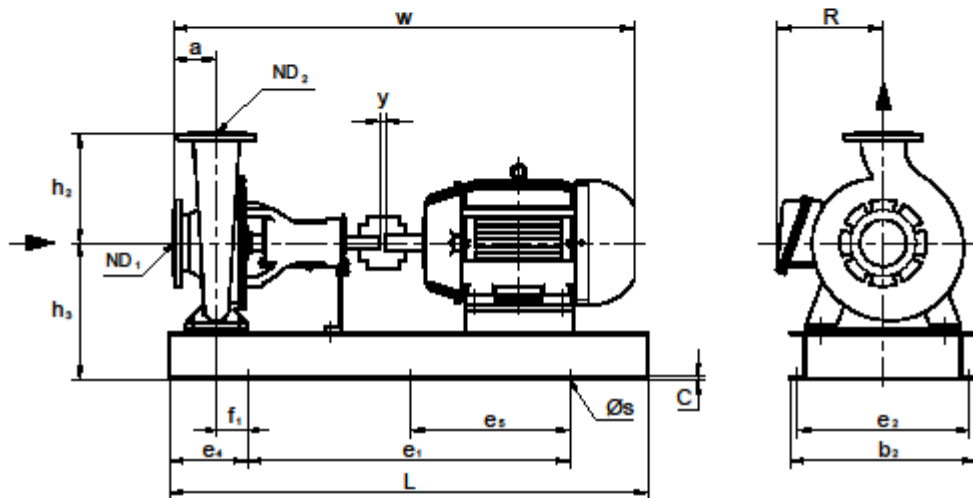

BOMBA	MOTOR	BASE	COPLER	$\alpha$	L	e1	e4	e2	e5	b2	h3	h2	ND2	ND1	f1	w	R	a	y	$\phi c$
32-125	71	1R	1030	10	900	550	155	320	-	365	227	140	32	50	93	718	126	80	3	16
	80															746	135	80	3	
	90L															799	150	80	3	
	100L															845	160	80	3	
112M	862	175	80	3																

\* MOTORES DE 2 POLOS  
(\* SOLO PARA EJECUCION S

MEDIDAS EN MM.

\*Todas las especificaciones son las vigentes al momento de la emisión de las mismas. Como nuestro objetivo es "La mejora continua", entregaremos el producto especificado o mejorado.

BOMBA CENTRIFUGA  
ISODIS 2856  
CATALOGO I

HIROSTAT S.A.  
PORTADA DEL SOL 722 - LIMA 36, PERU  
APARTADO POSTAL 3969 - LIMA 1, PERU  
E-MAIL: hidrostat@hidrostat.com.pe  
WEB: www.hidrostat.com.pe

VERSION B  
TELEFONO: (51-1) 319 10 00  
FAX: (51-1) 486 00 06  
FAX VENTAS: (51-1) 319 10 19  
SERVICIO AL CLIENTE SOLO PERU: 0801-10000



## ANEXO 7: ACEROS INOXIDABLES

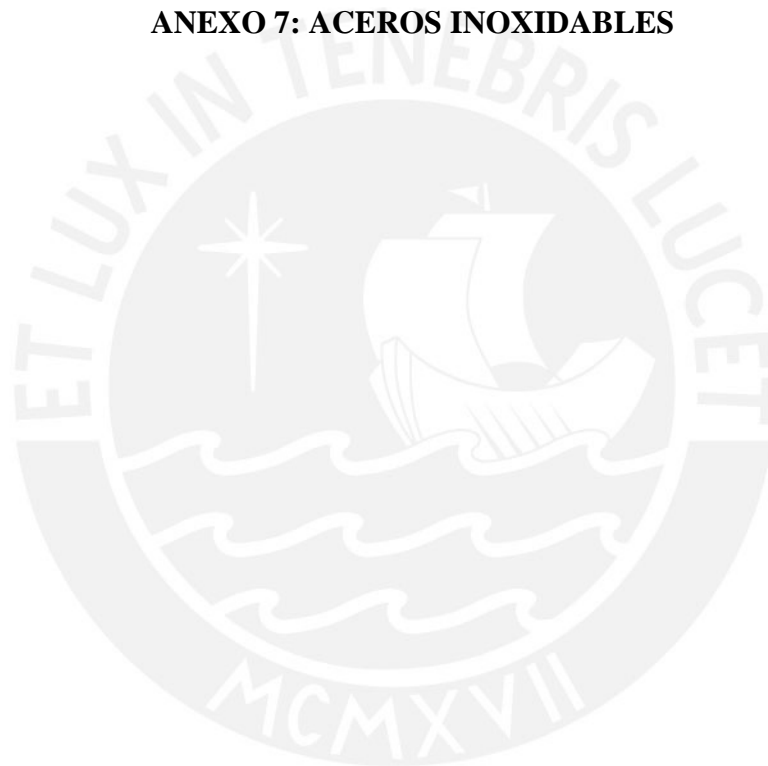



COTIZACIÓN : E03-1310021

- \* PLANCHAS
- \* TUBOS
- \* BARRAS
- \* ANGULOS
- \* PLATINAS
- \* ACCESORIOS
- \* SERVICIO DE CORTE Y DOBLEZ

Señores : ALICORP SAA  
 Atención : SR. JORGE JONATAN O. VIVAR CALLE  
 Dirección : AV. ARGENTINA # 4793 - CARMEN DE LA LEGUA REYNOSO  
 Fecha : 10/10/2013

Código : AL0001  
 Vendedor : Monica Atoche  
 Teléfono : 315-0800  
 Fax : 222-2535  
 Referencia :

Estimados Señores:  
 En atención a su amable solicitud de cotización, les presentamos nuestra siguiente oferta:

Item	Código	Descripción	Und	Cantidad	Preco	Total US\$
1	TB6G1L20	TUBO A. INOX. C-316L 8CH-40 C/C 1/2"	MT	6.000	9.05	54.30
ITEM 1: LLEGADA 2DA.SEMANA NOVIEMBRE						
2	36L10476	PL. A. INOX. C-316L 4.76mmx1220mmx2440mm No.1	PL	1.000	464.06	464.06
3	36L13812	PL. A. INOX. C-316L 38.10mmx1500mmx2997mm No.1	PL	1.000	6,157.24	6,157.24
4	36L00250	PL. A. INOX. C-316L 2.50mmx1220mmx2440mm 2B	PL	1.000	255.04	255.04
5	36L00300	PL. A. INOX. C-316L 3.00mmx1220mmx2440mm 2B	PL	1.000	306.04	306.04
6	36L11908	PL. A. INOX.C-316L 19.05mmx1500mmx3000mm No.1	PL	1.000	2,854.64	2,854.64
					Sub total	10,081.32
					I.G.V. 18.00 %	1,816.44
					<b>Total Cotización US\$</b>	<b>11,907.76</b>

El cliente podrá deducir del I.G.V. que le corresponda pagar, las percepciones que se le hubiera efectuado hasta el último día del periodo al que corresponda la declaración

**BRINDAMOS SERVICIO DE CORTE Y DOBLEZ DE ACUERDO A SUS NECESIDADES**

- Plazo de Entrega : Inmediata. Cliente recoge en nuestro Almacén
- Forma de Pago : CREDITO
- Validez de la Oferta : 01 DIA
- Observaciones : Pagadero en dólares americanos o nuevos soles al tipo de cambio vigente en la fecha de pago.

Sin otro particular y a la espera de vernos favorecidos con vuestra orden de compra nos despedimos de Uds.

Atentamente,

Monica Atoche  
 Ejecutivo de Ventas  
 Nextel: 832\*4841

**AHORRE DINERO Y TIEMPO, CONSULTE POR NUESTRO  
 NUEVO SERVICIO DE CORTE POR CHORRO DE AGUA**

**PLANCHAS** Normas: ASTM A-240/A-480

Espesor Nominal		Ancho x Largo 1,219mm x 2,438mm 4' x 8'		Ancho x Largo 1,524mm x 3,048mm 5' x 10'		Calidades de uso Frecuente		Espesor Nominal		Ancho x Largo 1,219mm x 2,438mm 4' x 8'		Ancho x Largo 1,524mm x 3,048mm 5' x 10'		Calidades de uso Frecuente					
mm	Aprox. Pulg.	Kg.	Kg.	Tipo	mm	Aprox. Pulg.	Kg.	Kg.	Tipo	mm	Aprox. Pulg.	Kg.	Kg.	Tipo					
0.30	1/85	7.133	11.148	430,304, 304L	3.00	1/8	71.326	111.484	304, 304L, 316, 316L	0.40	1/64	9.510	14.864	430,304, 304L	4.00	5/32	95.102	148.645	304, 304L, 316, 316L
0.40	1/64	9.510	14.864	430,304, 304L	0.45	1/57	10.699	16.723	430,304, 304L	4.76	3/16	113.171	176.887	430,304, 304L	6.00	1/4	142.652	222.97	304, 304L, 316, 316L
0.45	1/57	10.699	16.723	430,304, 304L	0.50	1/54	11.888	18.581	430,304, 304L	6.00	1/4	142.652	222.97	430,304, 304L	7.90	5/16	167.825	293.574	304, 304L, 316, 316L
0.50	1/54	11.888	18.581	430,304, 304L	0.54	1/46	12.839	20.067	430,304, 304L	7.90	5/16	167.825	293.574	430,304, 304L	9.52	3/8	226.342	353.775	304, 304L, 316, 316L
0.54	1/46	12.839	20.067	430,304, 304L	0.60	1/40	14.265	22.297	430,304, 304L	9.52	3/8	226.342	353.775	430,304, 304L	12.00	-	285.305	445.930	304, 304L, 316, 316L
0.60	1/40	14.265	22.297	430,304, 304L	0.70	1/36	16.643	26.013	430,304, 304L	12.00	-	285.305	445.930	430,304, 304L	12.70	1/2	301.947	471.947	304, 304L, 316, 316L
0.70	1/36	16.643	26.013	430,304, 304L	0.80	1/32	19.020	29.729	430,304, 304L	12.70	1/2	301.947	471.947	430,304, 304L	19.05	3/4	452.921	707.921	304, 304L, 316, 316L
0.80	1/32	19.020	29.729	430,304, 304L	0.90	1/27	21.398	33.445	304, 304L	19.05	3/4	452.921	707.921	304, 304L	25.00	-	594.384	929.030	304, 304L, 316, 316L
0.90	1/27	21.398	33.445	304, 304L	1.00	1/24	23.775	37.161	304, 304L	25.00	-	594.384	929.030	304, 304L	25.40	1	603.895	943.890	304, 304L, 316, 316L
1.00	1/24	23.775	37.161	304, 304L	1.20	1/20	28.530	44.593	304, 304L, 316, 316L	25.40	1	603.895	943.890	304, 304L, 316, 316L	31.75	1-1/4	754.868	1179.869	304, 304L, 316, 316L
1.20	1/20	28.530	44.593	304, 304L, 316, 316L	1.50	1/16	35.663	55.742	304, 304L, 316, 316L	31.75	1-1/4	754.868	1179.869	304, 304L, 316, 316L	38.10	1-1/2	905.842	1415.842	304, 304L, 316, 316L
1.50	1/16	35.663	55.742	304, 304L, 316, 316L	2.00	5/64	47.551	74.322	304, 304L, 316, 316L	38.10	1-1/2	905.842	1415.842	304, 304L, 316, 316L	50.80	2	1207.789	1887.79	304, 304L, 316, 316L
2.00	5/64	47.551	74.322	304, 304L, 316, 316L	2.50	3/32	59.438	92.903	304, 304L, 316, 316L	50.80	2	1207.789	1887.79	304, 304L, 316, 316L					

Tabla orientativa

**BOBINAS** Normas: ASTM A-240/A-480

SUMINISTRAMOS BOBINAS A PEDIDO DIRECTO A SOLICITUD DEL CLIENTE.

ACABADOS DE PLANCHAS Y BOBINAS	DESCRIPCION
Laminados en Caliente	N°1 Laminado en Caliente, recocido y decapado. Superficie mate - áspera. Utilizado en aplicaciones industriales de alta resistencia al calor y a la corrosión.
Laminados en Frio	2D Laminado en frío, recocido y decapado. Acabado deslustrado o mate. Conveniente para retener lubricantes en las superficies de las láminas que van a ser sujetas a operaciones de embutido profundo. 2B Laminado en frío, recocido, decapado con una ligera laminación en el tren skin-pass. Acabado ligeramente semibrillante. Utilizado en casi todas las aplicaciones, excepto las de embutido profundo. Es más fácil pulir que los acabados N1 y 2D. BA Laminado en frío, recocido en horno de atmósfera controlada. Acabado brillante obtenido por tratamiento térmico. Ideal para uso decorativo.
Esmerilado	N°4 Pulido con cintas abrasivas de gramo 150 a 400. Es un acabado esmerilado y satinado de uso decorativo, sanitario y general.

PROPIEDADES MECÁNICAS				ALGUNAS APLICACIONES
Resistencia a la Tracción N/mm <sup>2</sup>	Limite Elástico al 0.2% mín. N/mm <sup>2</sup>	Alargamiento Mínimo %	Dureza Máxima HB	
540 - 750	230	45	190	Industria alimentaria, tubería, menaje, médica y otros.
520 - 670	220	45	190	Industria alimentaria, tubería, menaje, médica, tubos y otros.
530 - 680	240	45	200	Industrias químicas, petroquímica, minera, refrigeración y otros.
540 - 620	240	45	200	Industrias químicas, petroquímica, minera, refrigeración, tubos y otros.
450 - 600	260	20	180	Cubertería, menaje, armarios, decoración interior.

NOTA: PARA CUALQUIER OTRO TIPO DE ACERO INOXIDABLE CONSULTAR AL DEPARTAMENTO DE CONTROL DE CALIDAD Y ATENCIÓN AL CLIENTE.



## ANEXO 8: VÁLVULAS DE BOLA INOXIDABLES





Valvulas de Bola y Nipples



La Molina, 08 de Octubre del 2013

Señores  
**ALICORP**  
Presente

Atención: **ING : JORGE VIVAR**  
Referencia: **A SU SOLICITUD**

Nos es grato cotizarles a Ustedes lo siguiente con un descuento especial:

ITEM	DESCRIPCIÓN	UND	CANT	PRECIO UNITARIO	TOTAL	TIEMPO DE ENTREGA
1	<b>VALVULAS DE BOLA DE 1/2" 8W FULL PORT</b>	UN	2	131.12	262.24	3 semanas
	BODY MATERIAL: STAINLESS STEEL 316 BOLA: STAINLESS STEEL 316 ASIEN TO: PTFE + 15 % GF VASTAGO: STAINLESS STEEL 316 PACKING ORING: PTFE CONEXIÓN : 1/2" SOLDABLE 3 PIEZAS PRESSURE RATING : 1000 PSI WOG (69 BAR) TEMPERATURA RATING : -29 °C A 232 °C <b>MODELO 8700-F-05A-88-Q-B-HL</b> MARCA: MARWINVALVE					
2	<b>VALVULAS DE BOLA DE 1/2" 8W FULL PORT</b>	UN	1	1,248.00	1,248.00	3 semanas
	BODY MATERIAL: STAINLESS STEEL A351 CF8M BOLA: STAINLESS STEEL 316 ASIEN TO: CRPTFE VASTAGO: STAINLESS STEEL A479 8316 PACKING ORING: PTFE CONEXIÓN : 1/2" SOLDABLE 3 PIEZAS PRESSURE RATING : 4500 PSI WOG (310 BAR) TEMPERATURA RATING : -51 °C A 316 °C <b>MODELO 8000-F-050-88-8W-88-PK-TV-HL</b> MARCA: MARWINVALVE					
3	<b>VALVULAS DE BOLA DE 1/2" 8W FULL PORT</b>	UN	2	1,803.13	3,606.26	3 semanas
	BODY MATERIAL: STAINLESS STEEL A479 8316 BOLA: STAINLESS STEEL 316 ASIEN TO: PEEK VASTAGO: STAINLESS STEEL A479 8316 PACKING ORING: VITON CONEXIÓN : 1/2" SOLDABLE 3 PIEZAS PRESSURE RATING : 7000 PSI WOG (483 BAR) TEMPERATURA RATING : -51 °C A 316 °C <b>MODELO 10000-F-060-88-8W-88-PK-TV-HL</b> MARCA: MARWINVALVE					
4	<b>VALVULAS DE BOLA DE 1/2" 8W FULL PORT</b>	UN	4	131.12	524.48	3 semanas
	BODY MATERIAL: STAINLESS STEEL 316 BOLA: STAINLESS STEEL 316 ASIEN TO: PTFE + 15 % GF VASTAGO: STAINLESS STEEL 316 PACKING ORING: PTFE CONEXIÓN : 1/2" SOLDABLE 3 PIEZAS PRESSURE RATING : 1000 PSI WOG (69 BAR) TEMPERATURA RATING : -29 °C A 232 °C <b>MODELO 8700-F-05A-88-Q-B-HL</b> MARCA: MARWINVALVE					
5	<b>VALVULAS DE BOLA DE 1/2" 8W FULL PORT</b>	UN	2	131.12	262.24	3 semanas
	BODY MATERIAL: STAINLESS STEEL 316 BOLA: STAINLESS STEEL 316 ASIEN TO: PTFE + 15 % GF VASTAGO: STAINLESS STEEL 316 PACKING ORING: PTFE CONEXIÓN : 1/2" SOLDABLE 3 PIEZAS PRESSURE RATING : 1000 PSI WOG (69 BAR) TEMPERATURA RATING : -29 °C A 232 °C <b>MODELO 8700-F-05A-88-Q-B-HL</b> MARCA: MARWINVALVE					
<b>TOTAL</b>					<b>\$5,903.22</b>	

**Nota 1:** Los precios están basados en las cantidades e items ofertados.

**Nota 2:** No se aceptará devolución y/o anulación de la orden de compra, debido a que es una importación exclusiva para ALICORP

**Condiciones de la oferta:**

Página 1 de 2



Productos de válvulas  
de alta calidad





**Ball Valves**  
1000 psi WOG  
Threaded or Weld Ends  
Carbon or Stainless Steel

**8700 Series**  
Full Port  
2-Way  
3-Pc Body



**Features**

- Investment cast body construction
- ISO 5211 actuator mounting pad
- Blow-out proof stem
- Reinforced PTFE seats
- Adjustable, live loaded PTFE stem packing
- API 598 inspection and testing
- Locking lever operator

**Pressure-Temperature Ratings**

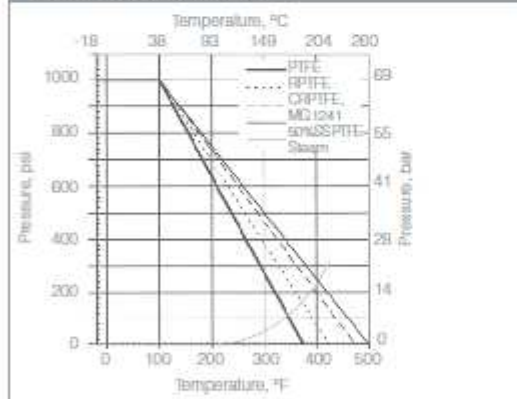

**Technical Specifications**

Valve Size Inches	Operating Torque, In-lb 250 - 1000 psi	Flow Coefficient, Cv
1/2"	45	17
3/4"	70	34
1"	130	57
1-1/4"	190	80
1-1/2"	250	143
2"	400	245

**8700F-XXX-CS Series Full Port Valve**

**8700F-XXX-S6 Series Full Port Valve**

Quick Spec	
<b>Product Scope</b>	
Size Range	1/2" - 2", Full Port
Body Type	3-pc, non swing-out w/ NPT ends (weld optional)
Pressure Rating	1000 psi WOG (69 bar)
Temperature Range / WSP	-20°F thru 450°F / 150 psi Steam -29°C thru 232°C / 10.3 bar Steam
Body	Stainless or Carbon Steel Body
Ball & Stem	Stainless Steel, Anti-Static Design
Ball Seats	RPTFE
Stem Packing & Seals	Adjustable, Live Loaded PTFE, w/Viton o-ring Stem & PTFE body
Operator/Mounting Pad	Manual Locking Lever / ISO 5211
<b>Design Standards</b>	
Design	ANSI B16.34, Class 600
Thread Design	ASME B1.20.1
<b>Testing Standards</b>	
Pressure Testing	API 598
<b>Approvals</b>	
CFR405539.5	

**Standard Materials of Construction**

Part	Carbon Steel	Stainless Steel
Body		
End Cap	WCB	CF8M
Seat	PTFE + 15% GF	
Ball	CF8M/316	
Stem	AISI 316	
Seat, Body	PTFE	
Thrust Washer	PTFE + 15% GF	
Packing	PTFE	
Belleville Spring Washer	AISI 301	
Gland Ring		
Handle, Locking	AISI 304	
Nut, Stem		
Stop Screw		
Cover, Handle	Vinyl	
Boil, Body	A2-70	
Lockwasher, Body		
Nut, Body	AISI 304	
Locking Tab		
O-Ring, Stem	Viton	
Antistatic Ball		
Antistatic Spring	AISI 316	
Name Plate	SS	

**Technical Specifications, metric**

Valve Size NPS	Operating Torque, N.m 17.2 - 68.9 bar	Flow Coefficient, Kv
DN15	5.1	14.6
DN20	7.9	29.2
DN25	14.7	49.0
DN32	21.5	68.8
DN40	29	123
DN50	45	211

Operating torques in table are for RPTFE seats. For PTFE seats, multiply by 0.87; for CRPTFE (15% Glass PTFE), MG1241 (5% Graphite, 20% Glass PTFE), and 50% SS PTFE, multiply by 1.09. Include an appropriate service factor for sizing actuators.

## 3000 Series Soft Seat MS3000 Series Metal Seat High Performance Ball Valves

The **3000 Series** soft seat valve is engineered for high pressure applications and has built-in versatility, offering a variety of seat/seal and body materials and end connections

- Sizes 1/4" through 3" full port and 1/4" through 4" standard port
- For applications with pressures to 4000 psi (275 bar); temperatures to 600°F (315°C). Ideal for hydraulic, gas, steam or process piping applications
- API 607, 4th Edition Fire Tested
- Available integral extended ends with "heat sink" construction allow in-place welding without damage to seats and seals
- Anti-static construction
- In addition to carbon and 316 stainless steel, available materials of construction include Alloy 20, Duplex, Hastelloy C, Monel, Titanium, 254SMO, Bronze and other alloys
- PED Category I available; consult factory



The **MS3000 Series** is a heavy duty, metal seated ball valve engineered for high pressure and temperature applications with an extended bonnet standard for pipe insulation and enhanced packing.

- Sizes 1/4" through 2" full port and 3" x 2" (sch. 160 pipe bore)
- For applications with pressures to 990 psi (69 bar); temperatures to 1000°F (538°C). Ideal for condensate, steam or gas service
- Wide variety of end connections
- The metal seats are identical upstream and downstream and can be interchanged during routine maintenance thereby extending the effective life
- Available with ANSI Class VI shutoff



Marwin Valve, a division of Richards Industries  
3170 Wasson Road • Cincinnati, OH 45209  
513.533.7340 • 800.628.2583 • 513.533.7343 #  
marwin@richardsind.com • www.marwinvalve.com



## 10000 Series Soft Seated MS10000 Series Metal Seat High Performance Ball Valves

The **10000 Series** soft seat valve is engineered for high pressure applications and has built-in versatility offering a center section capable of accepting flanged, socket weld, butt weld, or threaded end pieces.

- In sizes 1/4" through 2" (sch. 160 pipe bore) and 3" (same bore as 2" valve)
- Complies with ANSI B16.34, Class 2500 (1/4" – 1") and Class 1500 (1-1/4" – 3")
- For applications with pressures to 6000 psi (414 bar); temperatures to 600°F (315°C). Ideal for hydraulic, gas, steam or process piping applications.
- Wide variety of end connections including extended weld ends with "heat sink" construction to eliminate the need to disassemble valve for welding.
- Wide range of seat, seal and body materials including Carbon Steel, Stainless Steel, Duplex and other alloys.



10000 Series Soft Seated Valve with UT Actuator

The **MS10000 Series** is a metal seated three piece ball valve engineered for high pressure and temperature applications and offers standard extended bonnet for pipe insulation and enhanced packing, stem and handle for demanding service applications.

- In sizes 1/4" through 2" (sch. 160 pipe bore) and 3" (same bore as 2" valve)
- Complies with ANSI B16.34, Class 1500 (1/4" – 1") and Class 900 (1-1/4" – 3")
- For applications with pressures to 3700 psi (255 bar); temperatures to 1000°F (538°C). Ideal for water, gas or steam applications.
- Wide variety of end connections including extended weld ends with "heat sink" construction to eliminate the need to disassemble valve for welding.
- The metal seats are identical upstream and downstream and can be exchanged during routine maintenance thereby extending the effective life.
- Available with ANSI Class VI shutoff.



Cutaway MS10000 Series Metal Seated Ball Valve



**Marwin Valve, a division of Richards Industries**  
3170 Wasson Road • Cincinnati, OH 45209  
513-533-7340 • 800-628-2583 • 513-533-7343 (f)  
marwin@richardsind.com • www.marwinvalve.com

**ANEXO 9: VALORES MÁXIMOS PARA EL ESFUERZO ADMISIBLE ( $\sigma_{adm}$ )  
DE MATERIALES FERROSOS PARA UTILIZAR CON EL CÓDIGO ASME  
SECCIÓN VIII DIVISIÓN 1**



2011a SECTION II, PART D (METRIC)

TABLE 1A (CONT'D)  
SECTION I; SECTION III, CLASSES 2 AND 3; SECTION VIII, DIVISION 1; AND SECTION XII  
MAXIMUM ALLOWABLE STRESS VALUES S FOR FERROUS MATERIALS  
(\*See Maximum Temperature Limits for Restrictions on Class)

Line No.	Nominal Composition	Product Form	Spec No.	Type/Grade	Alloy Designation/ UNS No.	Class/ Condition/ Temper	Size/Thickness, mm	P-No.	Group No.
1	16Cr-12Ni-2Mo	Wld. pipe	SA-358	316L	S31603	1	...	0	1
2	16Cr-12Ni-2Mo	Smls. & wld. fittings	SA-403	316L	S31603	...	...	0	1
3	16Cr-12Ni-2Mo	Wld. pipe	SA-409	TP316L	S31603	...	...	0	1
4	16Cr-12Ni-2Mo	Bar	SA-479	316L	S31603	...	...	0	1
5	16Cr-12Ni-2Mo	Bar	SA-479	316L	S31603	...	...	0	1
6	16Cr-12Ni-2Mo	Wld. tube	SA-688	TP316L	S31603	...	...	0	1
7	16Cr-12Ni-2Mo	Wld. tube	SA-688	TP316L	S31603	...	...	0	1
8	16Cr-12Ni-2Mo	Wld. tube	SA-688	TP316L	S31603	...	...	0	1
9	16Cr-12Ni-2Mo	Wld. pipe	SA-813	TP316L	S31603	...	...	0	1
10	16Cr-12Ni-2Mo	Wld. pipe	SA-814	TP316L	S31603	...	...	0	1
11	16Cr-12Ni-2Mo	Castings	SA-351	CF8M	J42000	...	...	0	1
12	16Cr-12Ni-2Mo	Castings	SA-351	CF8M	J42000	...	...	0	1
(a) 13	16Cr-12Ni-2Mo	Cast pipe	SA-451	CPFaM	J42000	...	...	0	1
14	16Cr-12Ni-2Mo	Castings	SA-351	CF8M	J42900	...	...	0	1
15	16Cr-12Ni-2Mo	Castings	SA-351	CF8M	J42900	...	...	0	1
(a) 16	16Cr-12Ni-2Mo	Cast pipe	SA-451	CPFaM	J42900	...	...	0	1
17	16Cr-12Ni-2Mo	Forgings	SA-162	F316	S31600	...	> 125	0	1
18	16Cr-12Ni-2Mo	Forgings	SA-162	F316	S31600	...	> 125	0	1
19	16Cr-12Ni-2Mo	Forgings	SA-965	F316	S31600	...	...	0	1
20	16Cr-12Ni-2Mo	Forgings	SA-965	F316	S31600	...	...	0	1
21	16Cr-12Ni-2Mo	Forgings	SA-162	F316	S31600	...	≤ 125	0	1
22	16Cr-12Ni-2Mo	Forgings	SA-162	F316	S31600	...	≤ 125	0	1
23	16Cr-12Ni-2Mo	Smls. tube	SA-213	TP316	S31600	...	...	0	1
24	16Cr-12Ni-2Mo	Smls. tube	SA-213	TP316	S31600	...	...	0	1
25	16Cr-12Ni-2Mo	Plate	SA-240	316	S31600	...	...	0	1
26	16Cr-12Ni-2Mo	Plate	SA-240	316	S31600	...	...	0	1
27	16Cr-12Ni-2Mo	Wld. tube	SA-249	TP316	S31600	...	...	0	1
28	16Cr-12Ni-2Mo	Wld. tube	SA-249	TP316	S31600	...	...	0	1
29	16Cr-12Ni-2Mo	Wld. tube	SA-249	TP316	S31600	...	...	0	1
30	16Cr-12Ni-2Mo	Wld. tube	SA-249	TP316	S31600	...	...	0	1
31	16Cr-12Ni-2Mo	Smls. & wld. pipe	SA-312	TP316	S31600	...	...	0	1
32	16Cr-12Ni-2Mo	Smls. & wld. pipe	SA-312	TP316	S31600	...	...	0	1
33	16Cr-12Ni-2Mo	Wld. pipe	SA-312	TP316	S31600	...	...	0	1
34	16Cr-12Ni-2Mo	Wld. pipe	SA-312	TP316	S31600	...	...	0	1
35	16Cr-12Ni-2Mo	Wld. pipe	SA-358	316	S31600	1	...	0	1
36	16Cr-12Ni-2Mo	Smls. pipe	SA-376	TP316	S31600	...	...	0	1
37	16Cr-12Ni-2Mo	Smls. pipe	SA-376	TP316	S31600	...	...	0	1
38	16Cr-12Ni-2Mo	Smls. & wld. fittings	SA-403	316	S31600	...	...	0	1
39	16Cr-12Ni-2Mo	Wld. pipe	SA-409	TP316	S31600	...	...	0	1
40	16Cr-12Ni-2Mo	Bar	SA-479	316	S31600	...	...	0	1
41	16Cr-12Ni-2Mo	Bar	SA-479	316	S31600	...	...	0	1

2011a SECTION II, PART D (METRIC)

TABLE 1A (CONT'D)  
SECTION I; SECTION III, CLASSES 2 AND 3; \* SECTION VIII, DIVISION 1; AND SECTION XII  
MAXIMUM ALLOWABLE STRESS VALUES S FOR FERROUS MATERIALS  
(\*See Maximum Temperature Limits for Restrictions on Class)

Line No.	Min. Tensile Strength, MPa	Min. Yield Strength, MPa	Applicability and Max. Temperature Limits (NP = Not Permitted) (SPT = Supports Only)				External Pressure Chart No.	Notes
			I	III	VIII-1	XII		
1	485	170	NP	427	NP	NP	HA-4	G5
2	485	170	NP	427	454	343	HA-4	G5, W12, W14
3	485	170	NP	427	NP	NP	HA-4	G5
4	485	170	454	427	454	343	HA-4	G5, G22, G34
5	485	170	454	NP	454	343	HA-4	G22, G34
6	485	170	NP	427	NP	NP	HA-4	G5, W12
7	485	170	NP	NP	454	343	HA-4	G5, G24
8	485	170	NP	NP	454	343	HA-4	G24
9	485	170	NP	427	NP	NP	HA-4	G5, W12
10	485	170	NP	427	NP	NP	HA-4	G5, W12
11	485	205	NP	427	454	343	HA-4	G1, G5, G16, G17, G32
12	485	205	NP	NP	454	343	HA-4	G1, G32
13	485	205	NP	427	427	NP	HA-4	G1, G5, G16, G17, G32 (a)
14	485	205	816	427	816	343	HA-2	G1, G5, G12, G16, G17, G32, H1, T6
15	485	205	816	NP	816	343	HA-2	G1, G12, G32, H1, T6
16	485	205	NP	427	427	NP	HA-2	G1, G5, G16, G17, G32 (a)
17	485	205	816	427	816	343	HA-2	G5, G12, T6
18	485	205	816	NP	816	343	HA-2	G12, T6
19	485	205	816	427	816	343	HA-2	G5, G12, T6
20	485	205	816	NP	816	343	HA-2	G12, T6
21	515	205	816	427	816	NP	HA-2	G5, G12, T6
22	515	205	816	NP	816	NP	HA-2	G12, T6
23	515	205	816	427	816	NP	HA-2	G5, G12, T6
24	515	205	816	NP	816	NP	HA-2	G12, T6
25	515	205	816	427	816	343	HA-2	G5, G12, T6
26	515	205	816	NP	816	343	HA-2	G12, T6
27	515	205	816	NP	NP	NP	HA-2	G12, T6, W13
28	515	205	816	427	NP	NP	HA-2	G5, G12, T6, W12, W13
29	515	205	816	NP	816	343	HA-2	G3, G5, G12, G24, T7
30	515	205	816	NP	816	343	HA-2	G3, G12, G24, T9
31	515	205	816	427	816	343	HA-2	G5, G12, T6, W12, W13, W14
32	515	205	816	NP	816	343	HA-2	G12, T6, W13, W14
33	515	205	816	NP	816	343	HA-2	G3, G5, G12, G24, T7
34	515	205	816	NP	816	343	HA-2	G3, G12, G24, T9
35	515	205	NP	427	NP	NP	HA-2	G5, W12
36	515	205	816	427	816	343	HA-2	G5, G12, H1, T6, W12
37	515	205	816	NP	816	343	HA-2	G12, H1, T6
38	515	205	NP	427	816	343	HA-2	G5, G12, T6, W12, W14
39	515	205	NP	427	NP	NP	HA-2	G5, W12
40	515	205	816	427	816	343	HA-2	G5, G12, G22, H1, T6
41	515	205	816	NP	816	343	HA-2	G12, G22, H1, T6



2011a SECTION II, PART D (METRIC)

TABLE 1A (CONT'D)  
SECTION I; SECTION III, CLASSES 2 AND 3; SECTION VIII, DIVISION 1; AND SECTION XII  
MAXIMUM ALLOWABLE STRESS VALUES S FOR FERROUS MATERIALS  
(\*See Maximum Temperature Limits for Restrictions on Class)

Line No.	Maximum Allowable Stress, MPa (Multiply by 1000 to Obtain kPa), for Metal Temperature, °C, Not Exceeding														
	-30 to 40	65	100	125	150	200	250	300	325	350	375	400	425	450	475
1	115	115	115	115	115	109	103	98.0	95.7	94.1	92.8	90.9	89.0	87.8	...
2	115	115	115	115	115	109	103	98.0	95.7	94.1	92.8	90.9	89.0	87.8	86.6
3	115	115	115	115	115	109	103	98.0	95.7	94.1	92.8	90.9	89.0	87.8	...
4	115	115	115	115	115	109	103	98.0	95.7	94.1	92.8	90.9	89.0	87.8	86.6
5	115	106	96.3	91.3	87.4	81.2	76.0	72.5	71.2	70.0	68.8	67.5	66.3	65.0	63.8
6	115	115	115	115	115	109	103	98.0	95.7	94.1	92.8	90.9	89.0	87.8	...
7	97.9	97.9	97.9	97.9	97.9	93.0	87.2	82.9	81.6	80.2	78.4	77.2	75.9	74.7	73.4
8	97.9	90.3	82.1	77.8	74.3	68.7	64.8	61.4	60.4	59.7	58.4	57.2	55.9	55.2	54.7
9	115	115	115	115	115	109	103	98.0	95.7	94.1	92.8	90.9	89.0	87.8	...
10	115	115	115	115	115	109	103	98.0	95.7	94.1	92.8	90.9	89.0	87.8	...
11	138	138	138	136	134	133	129	119	116	114	112	111	110	108	107
12	138	128	117	111	107	98.5	92.7	88.2	86.1	84.4	83.2	82.0	81.1	80.2	79.5
(a) 13	138	138	138	136	134	133	129	119	116	114	112	111	110	108	...
14	138	138	138	136	134	133	129	119	116	114	112	111	110	108	107
15	138	128	117	111	107	98.5	92.7	88.2	86.1	84.4	83.2	82.0	81.1	80.2	79.5
(a) 16	138	138	138	136	134	133	129	119	116	114	112	111	110	108	...
17	138	138	138	136	134	133	126	119	116	114	112	111	110	108	108
18	138	128	118	112	107	99.2	92.8	88.1	86.1	84.1	82.9	82.0	81.4	80.6	79.8
19	138	138	138	136	134	133	126	119	116	114	112	111	110	108	108
20	138	128	118	112	107	99.2	92.8	88.1	86.1	84.1	82.9	82.0	81.4	80.6	79.8
21	138	138	138	138	138	134	126	119	116	114	112	111	110	108	108
22	138	128	118	112	107	99.2	92.8	88.1	86.1	84.1	82.9	82.0	81.4	80.6	79.8
23	138	138	138	138	138	134	126	119	116	114	112	111	110	108	108
24	138	128	118	112	107	99.2	92.8	88.1	86.1	84.1	82.9	82.0	81.4	80.6	79.8
25	138	138	138	138	138	134	126	119	116	114	112	111	110	108	108
26	138	128	118	112	107	99.2	92.8	88.1	86.1	84.1	82.9	82.0	81.4	80.6	79.8
27	138	128	118	112	107	99.2	92.8	88.1	86.1	84.1	82.9	82.0	81.4	80.6	79.8
28	138	138	138	138	138	134	126	119	116	114	112	111	110	108	108
29	117	117	117	117	117	114	107	101	99.0	96.8	95.7	94.4	93.1	92.5	91.4
30	117	109	99.8	94.9	90.8	84.0	78.8	74.7	73.3	72.1	70.8	69.6	69.0	68.4	67.7
31	138	138	138	138	138	134	126	119	116	114	112	111	110	108	108
32	138	128	118	112	107	99.2	92.8	88.1	86.1	84.1	82.9	82.0	81.4	80.6	79.8
33	117	117	117	117	117	114	107	101	99.0	96.8	95.7	94.4	93.1	92.5	91.4
34	117	109	99.8	94.9	90.8	84.0	78.8	74.7	73.3	72.1	70.8	69.6	69.0	68.4	67.7
35	138	138	138	138	138	134	126	119	116	114	112	111	110	108	...
36	138	138	138	138	138	134	126	119	116	114	112	111	110	108	108
37	138	128	118	112	107	99.2	92.8	88.1	86.1	84.1	82.9	82.0	81.4	80.6	79.8
38	138	138	138	138	138	134	126	119	116	114	112	111	110	108	108
39	138	138	138	138	138	134	126	119	116	114	112	111	110	108	...
40	138	138	138	138	138	134	126	119	116	114	112	111	110	108	108
41	138	128	118	112	107	99.2	92.8	88.1	86.1	84.1	82.9	82.0	81.4	80.6	79.8

**ANEXO 10: VALORES MÁXIMOS PARA EL ESFUERZO ADMISIBLE  
( $\sigma_{adm}$ ) DE MATERIALES FERROSOS PARA UTILIZAR CON EL CÓDIGO  
ASME SECCIÓN VIII DIVISIÓN 2**

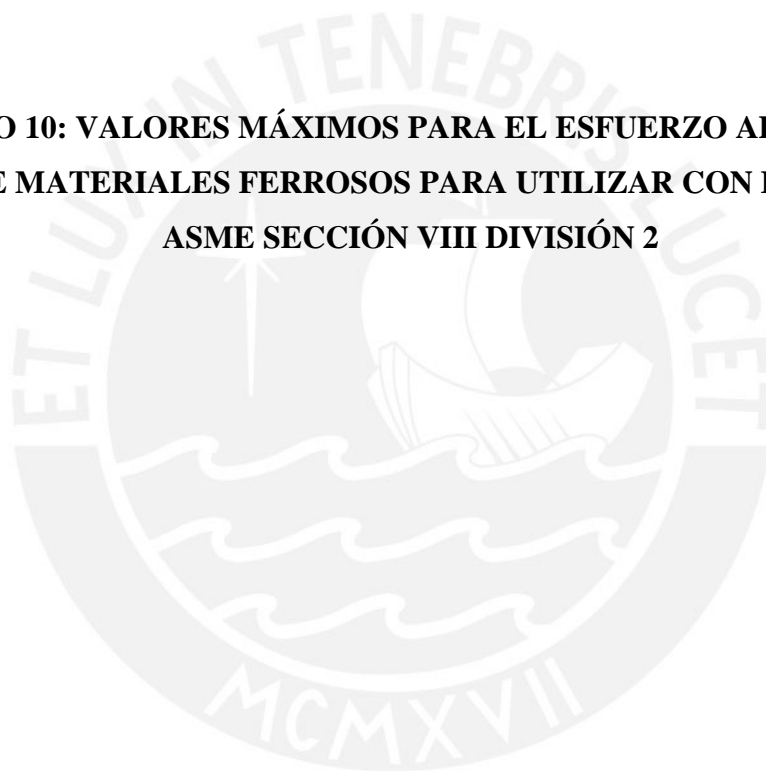

2011a SECTION II, PART D (METRIC)

TABLE 5A (CONT'D)  
SECTION VIII, DIVISION 2  
MAXIMUM ALLOWABLE STRESS VALUES  $S_m$  FOR FERROUS MATERIALS

Line No.	Nominal Composition	Product Form	Spec No.	Type/Grade	Alloy Designation/ UNS No.	Class/ Condition/ Temper	Size/Thickness, mm	P-No.	Group No.
1	9Ni	Fittings	SA-420	WPLa	K01340	...	...	11A	1
2	9Ni	Fittings	SA-420	WPLa	K01340	...	...	11A	1
3	9Ni	Forgings	SA-522	I	K01340	...	...	11A	1
4	9Ni	Forgings	SA-522	I	K01340	...	...	11A	1
5	9Ni	Plate	SA-555	I	K01340	...	...	11A	1
6	9Ni	Plate	SA-555	I	K01340	...	...	11A	1
7	16Cr-4Ni-6Mn	Plate	SA-240	201LN	S20155	...	...	8	3
8	16Cr-4Ni-6Mn	Plate	SA-240	201LN	S20155	...	...	8	3
9	16Cr-12Ni-2Mo	Forgings	SA-182	F316L	S31603	...	f > 125	8	1
10	16Cr-12Ni-2Mo	Forgings	SA-965	F316L	S31603	...	...	8	1
11	16Cr-12Ni-2Mo	Forgings	SA-182	F316L	S31603	...	f ≤ 125	8	1
12	16Cr-12Ni-2Mo	Smls. tube	SA-213	TP316L	S31603	...	...	8	1
13	16Cr-12Ni-2Mo	Plate	SA-240	316L	S31603	...	...	8	1
14	16Cr-12Ni-2Mo	Wld. tube	SA-249	TP316L	S31603	...	...	8	1
15	16Cr-12Ni-2Mo	Smls. pipe	SA-512	TP316L	S31603	...	...	8	1
16	16Cr-12Ni-2Mo	Wld. pipe	SA-512	TP316L	S31603	...	...	8	1
17	16Cr-12Ni-2Mo	Fittings	SA-403	316L	S31603	CR	...	8	1
18	16Cr-12Ni-2Mo	Wld. fittings	SA-403	316L	S31603	WP-W	...	8	1
19	16Cr-12Ni-2Mo	Wld. fittings	SA-403	316L	S31603	WP-WX	...	8	1
20	16Cr-12Ni-2Mo	Wld. pipe	SA-688	TP316L	S31603	...	...	8	1
21	16Cr-12Ni-2Mo	Castings	SA-351	CF8M	J02900	...	...	8	1
22	16Cr-12Ni-2Mo	Forgings	SA-182	F316	S31600	...	f > 125	8	1
23	16Cr-12Ni-2Mo	Forgings	SA-965	F316	S31600	...	...	8	1
24	16Cr-12Ni-2Mo	Forgings	SA-182	F316H	S31609	...	f > 125	8	1
25	16Cr-12Ni-2Mo	Forgings	SA-965	F316H	S31609	...	...	8	1
26	16Cr-12Ni-2Mo	Forgings	SA-182	F316	S31600	...	f ≤ 125	8	1
27	16Cr-12Ni-2Mo	Smls. tube	SA-213	TP316	S31600	...	...	8	1
28	16Cr-12Ni-2Mo	Plate	SA-240	316	S31600	...	...	8	1
29	16Cr-12Ni-2Mo	Wld. tube	SA-249	TP316	S31600	...	...	8	1
30	16Cr-12Ni-2Mo	Smls. pipe	SA-512	TP316	S31600	...	...	8	1
31	16Cr-12Ni-2Mo	Wld. pipe	SA-512	TP316	S31600	...	...	8	1
32	16Cr-12Ni-2Mo	Smls. pipe	SA-576	TP316	S31600	...	...	8	1
33	16Cr-12Ni-2Mo	Fittings	SA-403	316	S31600	WP-S	...	8	1
34	16Cr-12Ni-2Mo	Wld. tube	SA-688	TP316	S31600	...	...	8	1
35	16Cr-12Ni-2Mo	Forgings	SA-182	F316H	S31609	...	f > 125	8	1
36	16Cr-12Ni-2Mo	Smls. tube	SA-213	TP316H	S31609	...	...	8	1
37	16Cr-12Ni-2Mo	Wld. tube	SA-249	TP316H	S31609	...	...	8	1
38	16Cr-12Ni-2Mo	Smls. pipe	SA-512	TP316H	S31609	...	...	8	1
39	16Cr-12Ni-2Mo	Wld. pipe	SA-512	TP316H	S31609	...	...	8	1
40	16Cr-12Ni-2Mo	Smls. pipe	SA-576	TP316H	S31609	...	...	8	1
41	16Cr-12Ni-2Mo-N	Smls. tube	SA-213	TP316N	S31651	...	f ≤ 125	8	1
42	16Cr-12Ni-2Mo-N	Plate	SA-240	316N	S31651	...	f ≤ 125	8	1
43	16Cr-12Ni-2Mo-N	Wld. tube	SA-249	TP316N	S31651	...	...	8	1
44	16Cr-12Ni-2Mo-N	Smls. pipe	SA-512	TP316N	S31651	...	f ≤ 125	8	1
45	16Cr-12Ni-2Mo-N	Wld. pipe	SA-512	TP316N	S31651	...	f ≤ 125	8	1
46	16Cr-12Ni-2Mo-N	Smls. pipe	SA-576	TP316N	S31651	...	...	8	1

2011a SECTION II, PART D (METRIC)

TABLE 5A (CONT'D)  
SECTION VIII, DIVISION 2  
MAXIMUM ALLOWABLE STRESS VALUES  $S_w$  FOR FERROUS MATERIALS

Line No.	Min. Tensile Strength, MPa	Min. Yield Strength, MPa	Maximum Use Temperature, °C	External Pressure Chart No.	Notes
1	690	515	121	CS-3	W5
2	690	515	121	CS-3	W6
3	690	515	121	CS-3	G7, S2, W5
4	690	515	121	CS-3	G7, S2, W6
5	690	505	121	CS-3	W5
6	690	505	121	CS-3	W6
7	655	310	427	HA-6	---
8	655	310	427	HA-6	G2
9	450	170	454	HA-4	G2
10	450	170	454	HA-4	G2
11	485	170	454	HA-4	G2
12	485	170	454	HA-4	G2
13	485	170	454	HA-4	G2
14	485	170	454	HA-4	G2, G6
15	485	170	454	HA-4	G2
16	485	170	454	HA-4	G2, G6
17	485	170	454	HA-4	G2, G6
18	485	170	454	HA-4	G2, G6
19	485	170	454	HA-4	G2, G6
20	485	175	454	HA-4	G2, G6
21	485	205	516	HA-2	G2, G3, G4, G6, T10
22	485	205	516	HA-2	G2, T10
23	485	205	516	HA-2	G2, T10
24	485	205	516	HA-2	G2, T10
25	485	205	516	HA-2	G2, T10
26	515	205	516	HA-2	G2, G3, T10
27	515	205	516	HA-2	G2, G3, T10
28	515	205	516	HA-2	G2, G3, G4, T10
29	515	205	516	HA-2	G2, G3, G6, T10
30	515	205	516	HA-2	G2, G3, G4, T10
31	515	205	516	HA-2	G2, G3, G4, G6, T10
32	515	205	516	HA-2	G2, G3, G4, T10
33	515	205	516	HA-2	G2, T10
34	515	205	516	HA-2	G2, G3, G6, T10
35	515	205	516	HA-2	G2
36	515	205	516	HA-2	G2, T10
37	515	205	516	HA-2	G2, G6, T10
38	515	205	516	HA-2	G2, T10
39	515	205	516	HA-2	G2, G6, T10
40	515	205	516	HA-2	G2, G4, T10
41	550	240	649	HA-2	G2, T10
42	550	240	649	HA-2	G2, T10
43	550	240	649	HA-2	G2, G6, T10
44	550	240	649	HA-2	G2, T10
45	550	240	649	HA-2	G2, G6, T10
46	550	240	649	HA-2	G2, G4, T10



2011a SECTION II, PART D (METRIC)

TABLE 5A (CONT'D)  
SECTION VIII, DIVISION 2  
MAXIMUM ALLOWABLE STRESS VALUES  $S_m$  FOR FERROUS MATERIALS

Line No.	Maximum Allowable Stress, MPa (Multiply by 1000 to Obtain kPa), for Metal Temperature, °C, Not Exceeding																	
	-30 to 40	65	100	125	150	175	200	225	250	275	300	325	350	375	400	425	450	475
1	287	287	287	287	...	...	...	...	...	...	...	...	...	...	...	...	...	...
2	273	273	273	273	...	...	...	...	...	...	...	...	...	...	...	...	...	...
3	287	287	287	287	...	...	...	...	...	...	...	...	...	...	...	...	...	...
4	273	273	273	273	...	...	...	...	...	...	...	...	...	...	...	...	...	...
5	287	287	287	287	...	...	...	...	...	...	...	...	...	...	...	...	...	...
6	273	273	273	273	...	...	...	...	...	...	...	...	...	...	...	...	...	...
7	207	179	164	157	151	147	143	141	139	137	134	131	127	123	119	115	112	...
8	207	207	207	207	203	198	194	190	187	185	181	176	172	167	161	156	151	...
9	115	115	115	115	115	113	109	106	103	100	98.1	96.1	94.3	92.6	90.9	89.3	87.6	85.9
10	115	115	115	115	115	113	109	106	103	100	98.1	96.1	94.3	92.6	90.9	89.3	87.6	85.9
11	115	115	115	115	115	113	109	106	103	100	98.1	96.1	94.3	92.6	90.9	89.3	87.6	85.9
12	115	115	115	115	115	113	109	106	103	100	98.1	96.1	94.3	92.6	90.9	89.3	87.6	85.9
13	115	115	115	115	115	113	109	106	103	100	98.1	96.1	94.3	92.6	90.9	89.3	87.6	85.9
14	97.7	97.7	97.7	97.7	97.7	96.2	92.8	89.9	87.4	85.2	83.4	81.7	80.2	78.7	77.3	75.9	74.4	73.0
15	115	115	115	115	115	113	109	106	103	100	98.1	96.1	94.3	92.6	90.9	89.3	87.6	85.9
16	97.7	97.7	97.7	97.7	97.7	96.2	92.8	89.9	87.4	85.2	83.4	81.7	80.2	78.7	77.3	75.9	74.4	73.0
17	97.7	97.7	97.7	97.7	97.7	96.2	92.8	89.9	87.4	85.2	83.4	81.7	80.2	78.7	77.3	75.9	74.4	73.0
18	97.7	97.7	97.7	97.7	97.7	96.2	92.8	89.9	87.4	85.2	83.4	81.7	80.2	78.7	77.3	75.9	74.4	73.0
19	97.7	97.7	97.7	97.7	97.7	96.2	92.8	89.9	87.4	85.2	83.4	81.7	80.2	78.7	77.3	75.9	74.4	73.0
20	97.7	97.7	97.7	97.7	97.7	96.2	92.8	89.9	87.4	85.2	83.4	81.7	80.2	78.7	77.3	75.9	74.4	73.0
21	138	138	138	138	138	138	134	129	125	122	119	116	114	112	111	110	109	108
22	138	138	138	138	138	138	134	129	125	122	119	116	114	112	111	110	109	108
23	138	138	138	138	138	138	134	129	125	122	119	116	114	112	111	110	109	108
24	138	138	138	138	138	138	134	129	125	122	119	116	114	112	111	110	109	108
25	138	138	138	138	138	138	134	129	125	122	119	116	114	112	111	110	109	108
26	138	138	138	138	138	138	134	129	125	122	119	116	114	112	111	110	109	108
27	138	138	138	138	138	138	134	129	125	122	119	116	114	112	111	110	109	108
28	138	138	138	138	138	138	134	129	125	122	119	116	114	112	111	110	109	108
29	117	117	117	117	117	117	114	110	107	104	101	98.9	97.1	95.6	94.3	93.2	92.3	91.5
30	138	138	138	138	138	138	134	129	125	122	119	116	114	112	111	110	109	108
31	117	117	117	117	117	117	114	110	107	104	101	98.9	97.1	95.6	94.3	93.2	92.3	91.5
32	138	138	138	138	138	138	134	129	125	122	119	116	114	112	111	110	109	108
33	138	138	138	138	138	138	134	129	125	122	119	116	114	112	111	110	109	108
34	117	117	117	117	117	117	114	110	107	104	101	98.9	97.1	95.6	94.3	93.2	92.3	91.5
35	138	138	138	138	138	138	134	129	125	122	119	116	114	112	111	...	...	...
36	138	138	138	138	138	138	134	129	125	122	119	116	114	112	111	110	109	108
37	117	117	117	117	117	117	114	110	107	104	101	98.9	97.1	95.6	94.3	93.2	92.3	91.5
38	138	138	138	138	138	138	134	129	125	122	119	116	114	112	111	110	109	108
39	117	117	117	117	117	117	114	110	107	104	101	98.9	97.1	95.6	94.3	93.2	92.3	91.5
40	138	138	138	138	138	138	134	129	125	122	119	116	114	112	111	110	109	108
41	161	161	161	161	161	161	161	160	155	151	147	144	141	138	135	133	130	128
42	161	161	161	161	161	161	161	160	155	151	147	144	141	138	135	133	130	128
43	137	137	137	137	137	137	137	136	132	128	125	122	120	117	115	113	111	109
44	161	161	161	161	161	161	161	160	155	151	147	144	141	138	135	133	130	128
45	137	137	137	137	137	137	137	136	132	128	125	122	120	117	115	113	111	109
46	161	161	161	161	161	161	161	160	155	151	147	144	141	138	135	133	130	128

## ANEXO 11: TUBERÍAS INOXIDABLES AISI 316 SIN COSTURA



## NOMINAL WORKING PRESSURES

### BURSTING PRESSURES

$$P = \frac{2 \times S \times t}{D}$$

P = Pressure Rating (MPa)

S = Minimum Tensile Strength (MPa)

t = Wall thickness (mm)

D = Outside Diameter of Pipe (mm)

Figures shown in the following tables are nominal working pressures for seamless stainless steel pipe under constant operating conditions.

Where pressures or temperature fluctuations occur increased safety factors should be adopted. Listed below are "Factors of safety" recommended for varying pressure conditions.

- 5 to bursting pressure for no pressure fluctuations.
- 8 to bursting pressure for small/regular pressure fluctuations.
- 12 to bursting pressure for large/prolonged pressure fluctuations.

The figures given for nominal working pressures and factor of safety are for quick reference purposes only. Detailed design calculations should be in accordance with the applicable design standard.

Nominal working pressures for welded pipe can be calculated by multiplying the figure in the tables by 0.85 (weld joint efficiency factor).

Calculations have been formulated by using figures obtained from the Australian Pressure Piping Code AS 4041.

### SEAMLESS PIPE NOMINAL WORKING PRESSURES (MPa) FOR GRADES 316, 304 AND 321

NOMINAL BORE SIZE MM INCH	SCHEDULE 10S TEMPERATURE DEG C								SCHEDULE 40S TEMPERATURE DEG C								SCHEDULE 80S TEMPERATURE DEG C							
	50	100	150	200	250	300	350	400	50	100	150	200	250	300	350	400	50	100	150	200	250	300	350	400
6 1/8	30.1	26.8	23.4	21.7	20.2	19.2	18.5	17.9	42.0	37.3	32.6	30.3	28.2	26.7	25.9	25.0	58.6	52.0	45.5	42.2	39.3	37.3	36.0	34.8
8 1/4	30.1	26.8	23.4	21.7	20.2	19.2	18.5	17.9	40.8	36.3	31.8	29.5	27.5	26.0	25.2	24.3	55.2	49.0	42.8	39.7	37.0	35.1	33.9	32.8
10 3/8	24.1	21.4	18.7	17.4	16.2	15.4	14.9	14.4	33.8	30.0	26.2	24.3	22.7	21.5	20.8	20.1	46.8	41.6	35.4	33.7	31.4	29.8	28.8	27.8
15 1/2	24.8	22.0	19.2	17.9	16.6	15.9	15.3	14.7	32.5	28.9	25.3	23.4	21.8	20.7	20.0	19.3	43.8	38.9	34.0	31.6	29.4	27.9	27.0	26.0
20 3/4	19.8	17.6	15.4	14.2	13.3	12.6	12.2	11.8	26.9	23.9	20.8	19.4	18.1	17.1	16.6	16.0	36.6	32.5	28.4	26.4	24.6	23.3	22.6	21.8
25 1	20.8	18.4	16.1	14.9	13.9	13.2	12.8	12.3	25.3	22.5	19.7	18.2	17.0	16.1	15.6	15.1	34.1	30.3	26.5	24.6	22.9	21.7	21.0	20.3
32 1-1/4	16.4	14.6	12.8	11.9	11.0	10.5	10.1	9.8	21.1	18.7	16.4	15.2	14.2	13.4	13.0	12.5	28.8	25.5	22.3	20.7	19.3	18.3	17.7	17.1
40 1-1/2	14.4	12.7	11.1	10.3	9.6	9.1	8.8	8.5	19.1	16.9	14.8	13.7	12.8	12.1	11.7	11.3	26.3	23.4	20.4	19.0	17.7	16.7	16.2	15.6
50 2	11.5	10.2	8.9	8.3	7.7	7.3	7.1	6.8	16.2	14.4	12.6	11.7	10.9	10.3	10.0	9.6	23.0	20.4	17.8	16.6	15.4	14.6	14.1	13.7
65 2-1/2	10.5	9.3	8.1	7.5	7.0	6.7	6.4	6.2	17.7	15.7	13.7	12.7	11.9	11.3	10.9	10.5	24.0	21.3	18.7	17.3	16.1	15.3	14.8	14.3
80 3	8.6	7.6	6.7	6.2	5.8	5.5	5.3	5.1	15.5	13.7	12.0	11.1	10.4	9.8	9.5	9.2	21.5	19.1	16.7	15.5	14.4	13.7	13.2	12.8
90 3-1/2	7.5	6.7	5.9	5.4	5.0	4.8	4.6	4.5	14.1	12.6	11.0	10.2	9.5	9.0	8.7	8.4	19.9	17.7	15.4	14.3	13.4	12.7	12.2	11.8
100 4	6.7	5.9	5.2	4.8	4.5	4.2	4.1	4.0	13.2	11.7	10.2	9.5	8.8	8.4	8.1	7.8	18.7	16.6	14.5	13.5	12.6	11.9	11.5	11.1
125 5	6.0	5.3	4.7	4.3	4.0	3.8	3.7	3.6	11.6	10.3	9.0	8.4	7.8	7.4	7.1	6.9	16.9	15.0	13.1	12.2	11.3	10.7	10.4	10.0
150 6	5.1	4.5	3.9	3.6	3.4	3.2	3.1	3.0	10.6	9.4	8.2	7.6	7.1	6.7	6.5	6.3	16.3	14.5	12.7	11.7	11.0	10.4	10.0	9.7
200 8	4.3	3.8	3.3	3.1	2.9	2.7	2.6	2.6	9.3	8.3	7.3	6.7	6.3	5.9	5.7	5.6	14.5	12.9	11.3	10.4	9.7	9.2	8.9	8.6
250 10	3.8	3.4	3.0	2.8	2.6	2.4	2.4	2.3	8.5	7.5	6.6	6.1	5.7	5.4	5.2	5.0	11.6	10.3	9.0	8.4	7.9	7.4	7.2	6.9
300 12	3.5	3.1	2.7	2.5	2.4	2.2	2.2	2.1	7.4	6.5	5.7	5.3	4.9	4.7	4.5	4.4	9.8	8.7	7.6	7.1	6.6	6.2	6.0	5.8

### SEAMLESS PIPE NOMINAL WORKING PRESSURES (MPa) FOR GRADES 316, 304 AND 321

NOMINAL BORE SIZE MM INCH	SCHEDULE 160 TEMPERATURE DEG C								SCHEDULE XXS TEMPERATURE DEG C															
	50	100	150	200	250	300	350	400	50	100	150	200	250	300	350	400								
6 1/8																								
8 1/4																								
10 3/8																								
15 1/2	56.2	49.9	43.6	40.5	37.7	35.7	34.6	33.4	87.8	77.9	68.1	63.2	58.9	55.8	54.0	52.2								
20 3/4	52.1	46.3	40.5	37.5	35.0	33.2	32.1	31.0	73.3	65.1	56.9	52.8	49.2	46.6	45.1	43.6								
25 1	47.6	42.3	36.9	34.3	31.9	30.3	29.3	28.3	68.1	60.5	52.9	49.1	45.7	43.3	41.9	40.5								
32 1-1/4	37.7	33.4	28.2	27.1	25.3	24.0	23.2	22.4	57.5	51.1	44.6	41.4	38.6	36.9	35.4	34.2								
40 1-1/2	37.0	32.9	28.7	26.6	24.8	23.5	22.8	22.0	52.6	46.7	40.8	37.9	35.3	33.5	32.4	31.3								
50 2	36.3	32.2	28.2	26.1	24.4	23.1	22.3	21.6	45.9	40.8	35.7	33.1	30.8	29.2	28.3	27.3								
65 2-1/2	32.7	29.0	25.4	23.5	21.9	20.8	20.1	19.4	48.1	42.7	37.3	34.6	32.3	30.6	29.6	28.6								
80 3	31.3	27.8	24.3	22.6	21.0	19.9	19.3	18.6	42.9	38.1	33.3	30.9	28.8	27.3	26.4	25.5								
90 3-1/2																								
100 4	29.5	26.2	22.9	21.3	19.8	18.8	18.2	17.6																
125 5																								
150 6																								
200 8																								
250 10																								
300 12																								

## PIPE DIMENSIONS & WEIGHTS

### AMERICAN NATIONAL STANDARD STAINLESS STEEL PIPE

Nominal Bore	inches mm Outside Diameter	Wall thickness in mm		Theoretical inside diameter in mm		Weight in kg/m	
		5S	10S	40S	80S	160	XXS
6	10.3		1.34	1.73	2.41		
1/8	8.465		7.82	6.84	5.48		
			0.29	0.37	0.47		
8	13.7		1.65	2.24	3.02		
1/4	8.540		10.40	9.22	7.98		
			0.49	0.63	0.80		
10	17.1		1.65	2.31	3.2		
3/8	8.675		13.90	12.48	10.70		
			0.63	0.84	1.10		
15	21.34	1.65	2.11	2.77	3.73	4.78	7.47
1/2	8.840	18.04	17.12	16.80	13.98	11.78	6.40
		0.80	1.00	1.27	1.62	1.95	2.55
20	26.7	1.65	2.11	2.87	3.91	5.56	7.82
3/4	1.050	23.40	22.48	20.98	18.88	15.58	11.06
		1.03	1.28	1.60	2.20	2.90	3.64
25	33.4	1.65	2.77	3.38	4.55	6.35	9.00
1	1.315	30.10	27.88	26.64	24.30	20.70	15.22
		1.30	2.09	2.50	3.24	4.24	5.45
32	42.2	1.65	2.77	3.56	4.85	6.35	9.700
1-1/4	1.680	38.00	36.00	35.00	32.50	29.50	22.80
		1.65	2.70	3.39	4.47	5.67	7.77
40	48.2	1.65	2.77	3.68	5.08	7.14	10.15
1-1/2	1.900	44.00	42.00	40.84	38.04	33.92	27.90
		1.91	3.11	4.05	5.41	7.25	9.55
50	60.3	1.65	2.77	3.91	5.54	8.74	11.07
2	2.375	57.00	54.78	52.48	49.22	42.82	38.16
		2.40	3.23	5.44	7.48	11.11	13.44
65	73.0	2.11	3.05	5.18	7.01	9.53	14.02
2-1/2	2.875	68.78	66.00	62.68	58.98	53.94	44.96
		2.60	5.28	6.63	11.41	14.82	20.39
80	88.9	2.11	3.05	5.40	7.62	11.13	16.24
3	3.500	84.68	82.00	77.92	73.68	68.64	58.42
		4.51	6.45	11.29	15.27	21.35	27.68
90	101.6	2.11	3.05	5.74	8.08		
3-1/2	4.000	97.38	95.50	90.12	85.44		
		5.18	7.40	13.57	18.63		
100	114.3	2.11	3.05	6.02	8.66	13.40	
4	4.500	110.08	108.20	102.28	97.18	87.32	
		5.94	8.36	16.07	22.32	33.54	
125	141.3	2.77	3.40	6.55	9.53		
5	5.563	136.76	134.50	128.20	122.24		
		8.47	11.57	21.77	30.67		
150	168.3	2.77	3.40	7.11	10.07		
6	6.625	162.78	161.50	154.88	148.38		
		11.32	13.64	28.26	42.65		
200	219.1	2.77	3.78	8.18	12.70		
8	8.625	213.58	211.58	202.74	193.70		
		14.79	18.95	42.55	64.64		
250	273.1	3.40	4.10	9.27	12.70		
10	10.750	298.90	294.72	284.58	247.70		
		22.63	27.79	60.37	96.07		
300	323.0	3.06	4.57	9.53	12.70		
12	12.750	315.98	314.78	304.84	298.50		
		31.25	35.00	73.88	132.08		
350	355.6	3.06	4.78				
14	14.000	347.68	346.04				
		34.35	41.30				
400	405.4	4.10	4.78				
16	16.000	398.02	396.84				
		41.55	47.20				
450	457.0	4.10	4.78				
18	18.000	448.62	447.44				
		45.67	53.26				
500	508.0	4.78	5.54				
20	20.000	498.44	498.02				
		50.25	63.67				
550	559.0	4.78	5.54				
22	22.000	540.44	547.02				
		63.24	75.53				
600	610.0	5.54	6.35				
24	24.000	598.02	597.98				
		62.47	84.45				
750	762.0	6.35	7.92				
30	30.000	748.98	748.18				
		118.37	147.36				

Dimensions according to ANSI/ASME B36.10 for Stainless Steel Pipe.  
 Dimensions according to ANSI/ASME B36.10 for Welded and Seamless Wrought Steel Pipe.  
 Weights are given in kilograms per meter and are for carbon steel pipe with plain ends. The different grades of stainless steel permit considerable variations in weight. The austenitic stainless steels may be about 2% greater, and the ferritic stainless steels about 5% less than the values shown in the table.

Information obtained from the Australian Stainless Steel Development Association.



**ANEXO 12: CÁLCULOS DE LAS CONDICIONES TERMODINÁMICAS  
PARA LAS OPCIONES PROPUESTAS**



La selección de los equipos más adecuados para la extracción de la oleorresina de pprika mediante  $\text{CO}_2$  en estado supercrtico se necesita conocer los estados termodinmicos con los que trabaja el equipo en sus diferentes procesos en base a las condiciones recomendables para una extraccin eficiente de la pprika segn lo visto en la seccin 1.5, para esto evaluaremos la mejor opcin tcnica-econmica:

### A-12.1. Primera solucin propuesta

La primera opcin que se analizar es llegar mediante un sistema de bombeo y un intercambiador de calor a las condiciones recomendadas para la extraccin de la oleorresina de pprika ( $P_{\text{extraccin}} = 400 \text{ bar}$ ,  $T_{\text{extraccin}} = 55 \text{ }^\circ\text{C}$ ). Adems, se est considerando que el  $\text{CO}_2$  que quede despus de la separacin con la oleorresina de pprika, se deber poder reutilizar en el proceso. En la figura A-12.1 se muestra un diagrama de la primera opcin que tenemos para realizar la planta de extraccin.



Figura A-12.1: Esquema de los estados termodinmicos de la planta piloto. (Elaboracin propia)

a) Estado 1: En este estado el  $\text{CO}_2$  se encuentra en estado lquido saturado a una temperatura ambiente ( $T_{\text{amb}} = 20 \text{ }^\circ\text{C}$ ), el cual se debe encontrar acumulado en un tanque pulmn, para asegurar que la bomba siempre trabaje con carga. El  $\text{CO}_2$  es suministrado mediante una botella de dixido de carbono lquido, la cual se adquiere comercialmente como fuente de materia prima, as como tambin del  $\text{CO}_2$  que se recupere del proceso y se haga recircular. El estado de la sustancia en esta etapa se

encuentra definido por los siguientes parámetros:  $P_1 = 57,3$  bar,  $T_1 = 20^\circ$  C, líquido saturado ( $x = 0$ ).

b) Estado 2: En este estado el proceso consiste en asegurar que el  $\text{CO}_2$  se encuentre en todo momento en estado de líquido subenfriado, debido a que cualquier rastro de vapor sería suficiente para dañar la bomba por cavitación al momento de presurizar el fluido. Además, de acuerdo al estado 1, el líquido suministrado por la botella de  $\text{CO}_2$  líquido, se encuentra en estado de líquido saturado, lo cual quiere decir que al momento que la bomba requiera succionar el  $\text{CO}_2$  este entraría en estado vapor lo que haría que haría que la bomba cavite, para evitar esta situación debe haber una diferencia positiva de presión entre la presión del  $\text{CO}_2$  ( $P_{\text{CO}_2}$ ) y su respectiva presión de vapor ( $P_{\text{vap}}$ ).

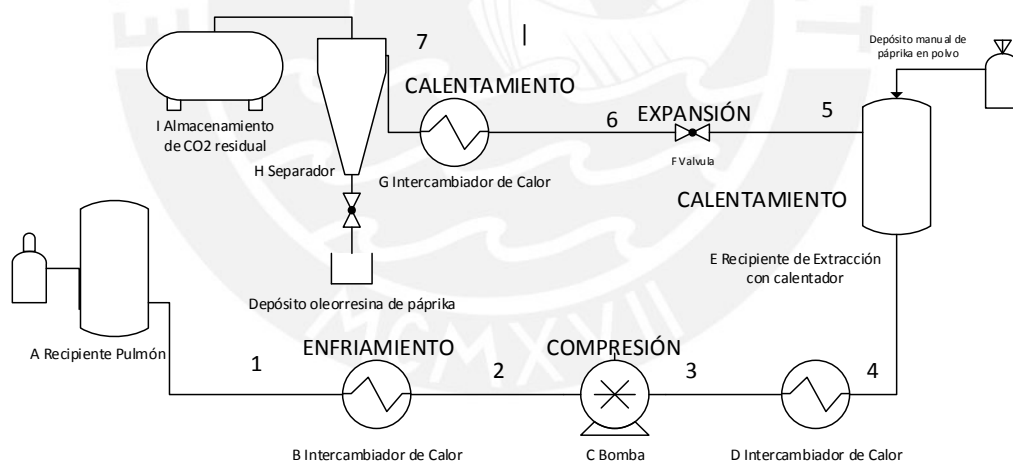
$$P_{\text{CO}_2} - P_{\text{vap}} > 0 \quad (\text{A-12.1})$$

En la figura A-12.2 se observa que si el estado 2', el cual es igual al estado 1, se comprime isoentrópicamente hasta la presión de 400 bar, se observa que el fluido alcanza una temperatura aproximada de  $55^\circ$  C en el estado 3', lo cual significa que el  $\text{CO}_2$  estaría en estado supercrítico al ser su presión y temperatura mayor que las críticas ( $P_{\text{crit}} = 57$  bar,  $T_{\text{crit}} = 31^\circ$  C), el cual al comportarse como una mezcla de líquido y gas, podría dañar la bomba.



Figura A-12.2: Análisis de los estados 2 y 3 para el proceso de extracción supercrítica.

[CHEMICALOGIC CORPORATION, 1999]

En el diagrama P-h, se puede deducir que la región comprendida en el lado izquierdo de la campana de líquido-vapor, el lado izquierdo de la línea de isotérmica de la temperatura crítica 31 °C y el lado derecho de la línea de fusión, debe ser la región de líquido subenfriado. En el estado 3 de la figura A-12.2 se muestra el estado crítico para una presión de 400 bar, en la cual la temperatura es aproximadamente la temperatura crítica ( $T_{crit} = 31 \text{ °C}$ ). Esto quiere decir que para estados que se encuentren en el diagrama P-h en la línea de 400 bar y se ubiquen al lado izquierdo de la línea isotérmica de  $T = 31 \text{ °C}$  (estado 3) se encuentran necesariamente en estado de líquido subenfriado, para alcanzar el estado 3 se debe comprimir el  $\text{CO}_2$  desde un estado 2 el cual se encuentra a  $P_2 = 57.3 \text{ bar}$  y a  $T_2 = 5 \text{ °C}$ . El proceso 1-2 consiste en una reducción de temperatura isobárica mediante la utilización de un intercambiador de calor, por lo que el estado de la sustancia en esta etapa se encuentra definido por los siguientes parámetros:  $P_2 = P_1 = 57.3 \text{ bar}$ ,  $T_2 = 5 \text{ °C}$ , líquido subenfriado.

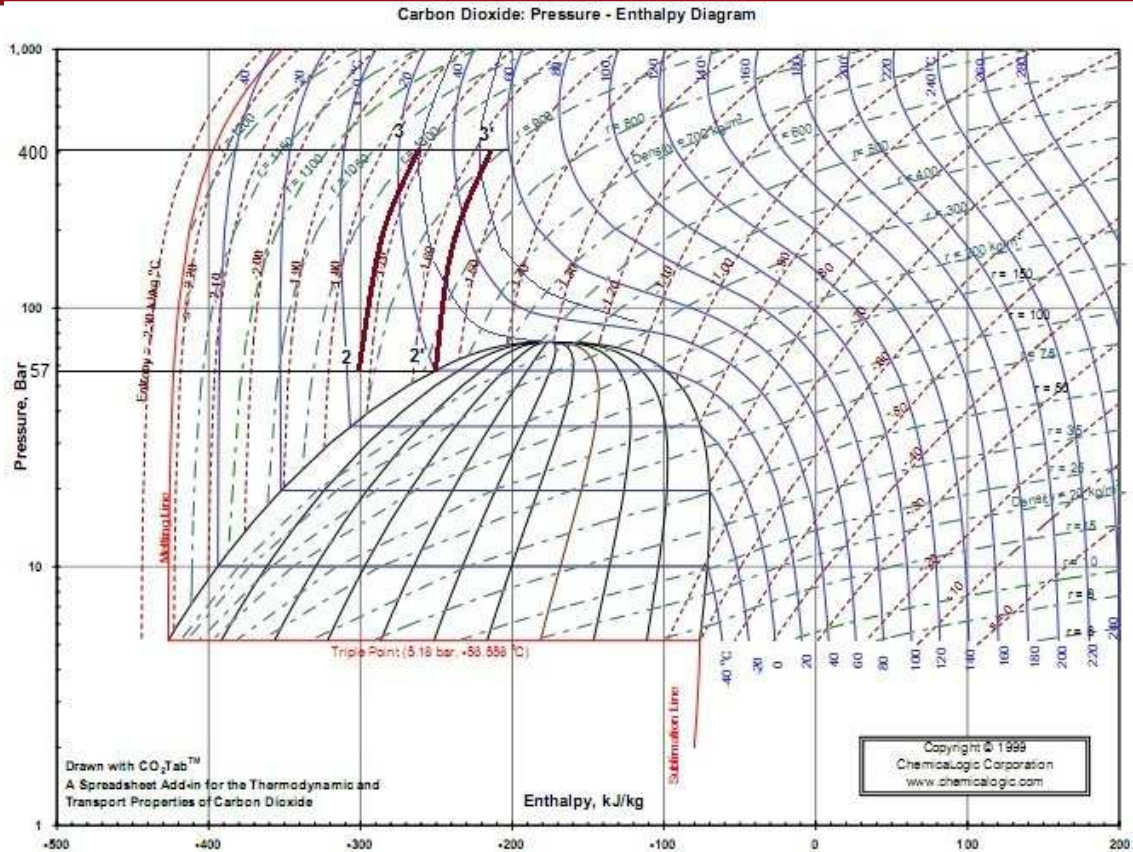

- c) Estado 3: En este estado el proceso consiste en comprimir al  $\text{CO}_2$  hasta una presión mayor a la presión crítica ( $P_{\text{crit}} = 71,7 \text{ bar}$ ) con el propósito de preparar al  $\text{CO}_2$  para que alcance el estado supercrítico. De acuerdo a lo visto en el capítulo 1, la presión de trabajo será de 400 bar, la cual es la temperatura requerida para lograr una máxima eficiencia en la extracción de la oleorresina de pprika. Se asumirá que el proceso 2-3 es una compresión isoentrpica, por lo que el estado de la sustancia en esta etapa se encuentra definido por los siguientes parmetros:  $P_3 = 400 \text{ bar}$ ,  $s_3 = s_2$
- d) Estado 4: En este estado el proceso consiste en brindarle al  $\text{CO}_2$  previamente presurizado en el estado 3 una temperatura mayor a la temperatura crtica ( $T_{\text{crit}} = 31^\circ \text{ C}$ ), para que el  $\text{CO}_2$  alcance el estado supercrtico y se pueda comenzar con el proceso de extraccin. De acuerdo a lo visto en el captulo anterior, la temperatura de extraccin ptima para conseguir la oleorresina de pprika es de  $55^\circ \text{ C}$ , que es la temperatura de trabajo para esta planta piloto. El proceso 3-4 consiste en aumentarle la temperatura isobricamente al  $\text{CO}_2$  mediante la utilizacin de un intercambiador de calor, por lo que el estado de la sustancia en esta etapa se encuentra definido por los siguientes parmetros:  $P_4 = P_3 = 400 \text{ bar}$ ,  $T_4 = 55^\circ \text{ C}$ .
- e) Estado 5: En este estado el proceso consiste en despresurizar el  $\text{CO}_2$  para que abandone el estado supercrtico para su posterior separacin de la oleorresina de pprika. Se desea bajar la presin mediante una vlvula reductora hasta una presin lo ms baja posible para de esta manera reducir lo mximo posible su densidad y por lo tanto su capacidad de disolver. Sin embargo, se observa que si el  $\text{CO}_2$  se expande isoentpicamente hasta presiones menores de 70 bar a partir del estado 4, este entrar dentro de la campana de mezcla lquido-vapor, por lo que dificultar su separacin con la oleorresina de pprika debido a que se deber buscar un mtodo de separacin para el  $\text{CO}_2$  gas que es menos denso y con menor capacidad de disolver como para el  $\text{CO}_2$  lquido que es ms denso y por lo tanto cuenta con mejores propiedades como disolvente. De la misma manera, se observa que para presiones menores a 5 bar el  $\text{CO}_2$  pasa a formar una mezcla de gas slido, lo que dificultar incluso ms el proceso de extraccin. Por este motivo se buscar reducir a presiones que estn en el rango de 5,5 – 10 bar. El proceso 4-5 ser una expansin isoentpica, por lo que el estado de la sustancia en esta etapa se encuentra definido por los siguientes parmetros:  $P_5 = 8 \text{ bar}$ ,  $h_5 = h_4$ .

$$x_5 = \frac{h_5 - h_f}{h_g - h_f} = 0,574 \quad (\text{A-12.2})$$

f) Estado 6: En este estado el proceso consiste en calentar el CO<sub>2</sub> para llevarlo al estado gaseoso para de esta manera reducir su densidad y consecuentemente su capacidad para disolver. El tener que dejar el CO<sub>2</sub> como una mezcla vapor-líquido dificultaría el proceso de separación entre el CO<sub>2</sub> y la oleorresina de p  prika ya que en ese caso se deber  a buscar un proceso de separaci  n para el CO<sub>2</sub> gaseoso y otro proceso de separaci  n para el CO<sub>2</sub> l  quido, para asegurar que el CO<sub>2</sub> se mantenga en estado gaseoso en todo el proceso de separaci  n y que nada se lic  e, se elevar   la presi  n unos 5   C m  s del estado de vapor saturado. El proceso 5-6 consistir   en un aumento de temperatura isob  rica, por lo que el estado de la sustancia en esta etapa se encuentra definido por los siguientes par  metros: P<sub>6</sub> = P<sub>5</sub> = 8 bar, T<sub>5</sub> = 25   C, vapor sobrecalentado.

En la figura A-12.3, se encuentran graficado todo el proceso t  rmico que se realizar   como opci  n 1 para la extracci  n de la oleorresina de p  prika en el diagrama P-h para el CO<sub>2</sub>.



Figura A-12.3: Proceso termodinámico de la primera opción para el proceso de extracción de oleorresina de pprika usando CO<sub>2</sub> en estado supercrtico. [CHEMICALOGIC CORPORATION, 1999]

En la tabla A-12.1 se observan los 7 estados del proceso de extraccin supercrtica usando CO<sub>2</sub>.

Tabla A-12.1: Estados termodinmicos para la primera opcin para el proceso de extraccin de oleorresina de pprika usando CO<sub>2</sub> en estado supercrtico. (Elaboracin propia)

Estados Termodinmicos para la 1 <sup>o</sup> Opcin de Proceso de Extraccin de Oleorresina de Pprika usando CO <sub>2</sub> Supercrtico				
Estados	T (° C)	P (bar)	h (kJ/kg)	x
1	20	57	-250	Lquido Saturado
2	5	57	-310	Lquido Subenfriado
3	30	400	-260	Lquido Subenfriado
4	55	400	-210	Fluido Supercrtico
5	-45	8	-210	57.40%
6	20	8	-10	Vapor Sobrecalentado

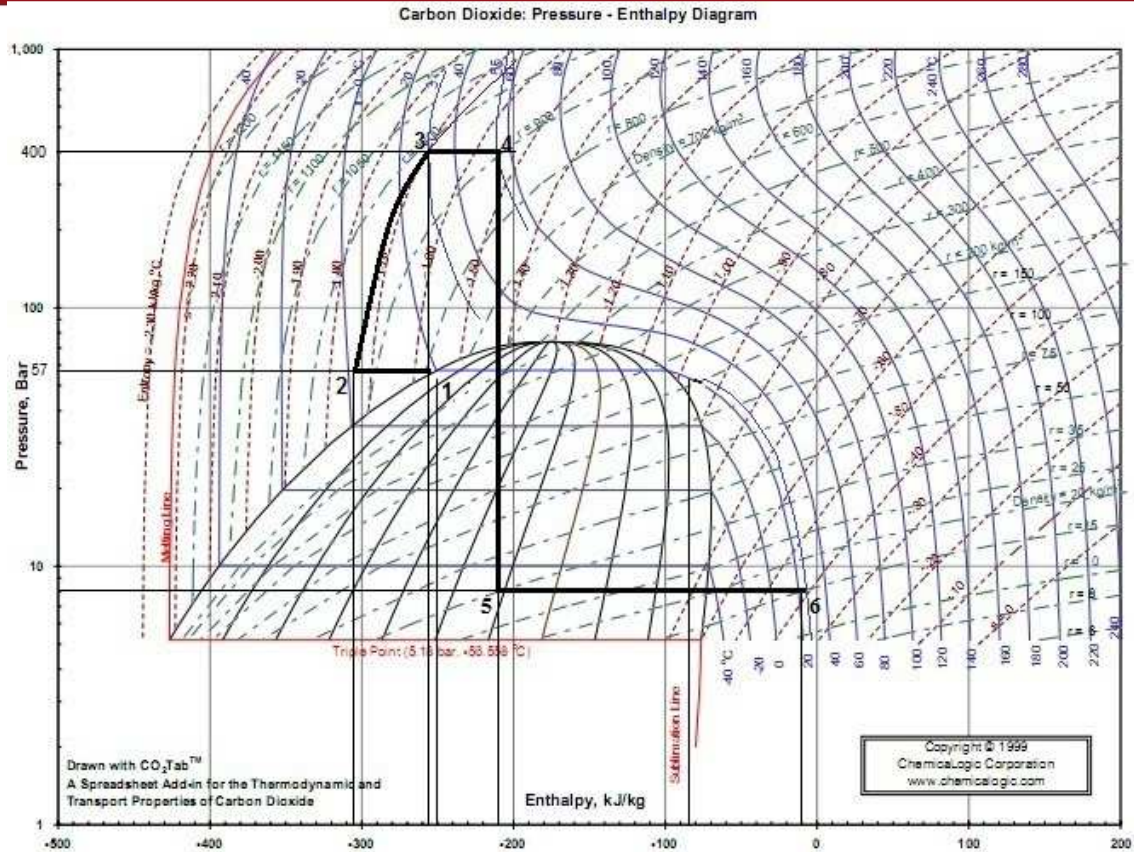
Limitaciones del proceso:

- Es complicado conseguir una bomba que pueda comprimir hasta 400 bar debido a su fabricacin ms robusta para que pueda soportar presiones de trabajo tan altas. Se necesitara necesariamente una bomba reciprocante para alcanzar presiones tan

altas, sin embargo, la mayoría de las bombas reciprocantes solamente alcanzan presiones de 345 bar (5000 psi).

- Es complicado conseguir un intercambiador de calor que pueda trabajar a 400 bar, debido a que la mayoría de fabricantes generalmente ofrecen intercambiadores que trabajan como máximo a 100 bar, se necesitaría importar un intercambiador de calor con estas características, debido a que ningún proveedor local ofrece un equipo para trabajar en estas condiciones, lo cual incrementaría más el costo para adquirir este equipo.

### A12.2. Segunda solución propuesta y definitiva

En la figura A-12.4 se muestra un diagrama de la segunda opción que tenemos para realizar la planta de extracción para oleoresina de paprika usando CO<sub>2</sub> en estado supercrıtico.



Figura A-12.4: Esquema de los estados termodinımicos de la planta piloto. (Elaboracion propia)

- Estado 1: En este estado el CO<sub>2</sub> se encuentra en estado lıquido saturado a una temperatura ambiente ( $T_{amb} = 20 \text{ }^\circ\text{C}$ ), el cual se debe encontrar acumulado en un tanque pulmon, para asegurar que la bomba siempre trabaje con carga. El CO<sub>2</sub> es suministrado mediante una botella de dioxido de carbono lıquido, la cual se adquiere comercialmente como fuente de materia prima, ası como tambien del CO<sub>2</sub> que se recupere del proceso y se haga recircular. El estado de la sustancia en esta etapa se

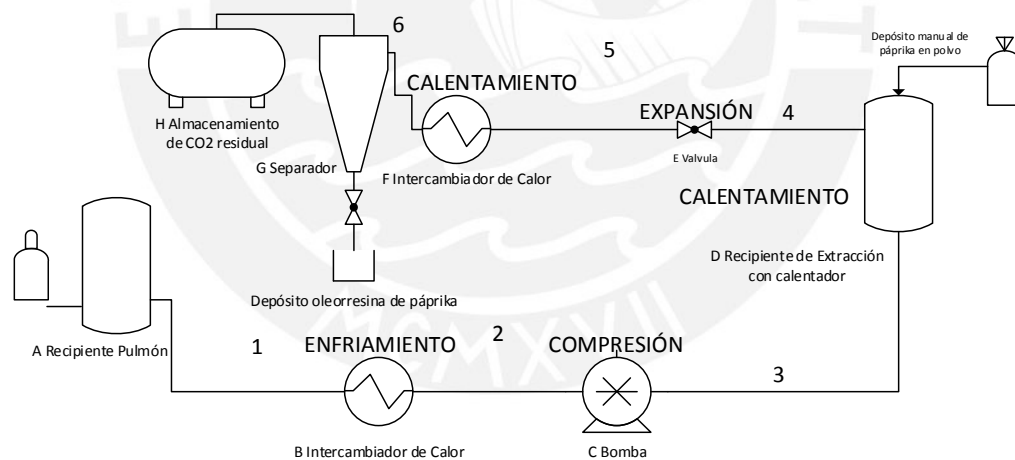

encuentra definido por los siguientes parámetros:  $P_1 = 57,3$  bar,  $T_1 = 20^\circ$  C, líquido saturado ( $x = 0$ ).

- Estado 2: En este estado el proceso consiste en asegurar que el  $\text{CO}_2$  se encuentre en todo momento en estado de líquido subenfriado, debido a que cualquier rastro de vapor sería suficiente para dañar la bomba por cavitación al momento de presurizar el fluido. Además, de acuerdo al estado 1, el líquido suministrado por la botella de  $\text{CO}_2$  líquido, se encuentra en estado de líquido saturado, lo cual quiere decir que al momento que la bomba requiera succionar el  $\text{CO}_2$  este entraría en estado vapor lo que haría que haría que la bomba Cavite, para evitar esta situación debe haber una diferencia positiva de presión entre la presión del  $\text{CO}_2$  ( $P_{\text{CO}_2}$ ) y su respectiva presión de vapor ( $P_{\text{vap}}$ ). Se puede notar que si se trata de bombear el  $\text{CO}_2$  en esas condiciones sea va a tener la dificultad de que la presión del líquido sería igual a la presión de evaporización, para lo cual se necesitaría una altura de succión positiva demasiado alta para cumplir con:

$$NPSH_{SIST} > NPSH_{REQ} \quad (A12.3)$$

Como se trata del diseño de una planta piloto no es posible diseñar un sistema de bombeo con una altura de succión positiva demasiado alta, se prefiere reducir un poco la temperatura mediante un intercambiador de calor con lo cual se gana una diferencia entre la nueva presión del  $\text{CO}_2$  y su respectiva presión de vapor para esa nueva temperatura, lo cual nos da la facilidad de diseñar con una pequeña altura de succión. El proceso 1-2 es una reducción de temperatura isobárica mediante un intercambiador de calor, por lo que el estado del  $\text{CO}_2$  en esta etapa se encuentra definido por los siguientes parámetros:  $P_2 = P_1 = 57,3$  bar,  $T_2 = 15^\circ$  C,  $P_v2 = 50$  bar, líquido subenfriado.

- Estado 3: En este estado el proceso consiste en aumentarle la presión al  $\text{CO}_2$  para que posteriormente el fluido ingrese al recipiente de extracción. Similar al análisis que se hizo en el estado 3 de la 1° opción, nos damos cuenta que si aumentamos adiabáticamente la presión a partir del estado 2 mediante una bomba, la temperatura también irá aumentando. Para estar seguros que el  $\text{CO}_2$  que pasa por la bomba siempre esté en estado líquido, lo comprimiremos hasta el punto más cercano

a su temperatura crítica ( $T_{crit} = 31\text{ °C}$ ). El punto escogido es  $T_3 = 30\text{ °C}$ . El proceso 2-3 es una compresión isoentrópica, por lo que el estado de la sustancia en esta etapa se encuentra definido por los siguientes parámetros:  $T_3 = 30\text{ °C}$ ,  $P_3 = 220\text{ bar}$ ,  $s_3 = s_2$ .

- Estado 4: En este estado el proceso consiste en brindarle al  $\text{CO}_2$  previamente presurizado y depositado en el recipiente de extracción una temperatura mayor a  $T_{crit} = 31\text{ °C}$ , para que el  $\text{CO}_2$  alcance el estado supercrítico y de esta manera se realice la extracción de la oleoresina de paprika por parte del  $\text{CO}_2$ . Al calentar el  $\text{CO}_2$  dentro del recipiente de extraccion, el cual es completamente hermetico, el volumen del fluido se mantendra constante, por lo tanto se experimentara un aumento de presion. De acuerdo a lo visto en el capıtulo 1, se escogeran las condiciones de mayor eficiencia para la extraccion de la oleoresina de paprika como condiciones de trabajo ( $P_{extraccion} = 400\text{ bar}$ ,  $T_{extraccion} = 55\text{ °C}$ ). El proceso 3-4 es un aumento de temperatura isocorico por lo que el estado de la sustancia en esta etapa se encuentra definido por los siguientes parametros:  $P_4 = 400\text{ bar}$ ,  $T_4 = 55\text{ °C}$ ,  $v_4 = v_3$ .

- Estado 5: En este estado el proceso consiste en despresurizar el  $\text{CO}_2$  para que abandone el estado supercrıtico para su posterior separacion de la oleoresina de paprika. Se desea bajar la presion mediante una valvula reductora hasta una presion lo mas baja posible para de esta manera reducir lo maximo posible su densidad y por lo tanto su capacidad de disolver. Sin embargo, se observa que si el  $\text{CO}_2$  se expande isoentalpica hasta presiones menores de 70 bar a partir del estado 4, este entrara dentro de la campana de mezcla lıquido-vapor, por lo que dificultara su separacion con la oleoresina de paprika debido a que se debera buscar un metodo de separacion para el  $\text{CO}_2$  gas que es menos denso y con menor capacidad de disolver como para el  $\text{CO}_2$  lıquido que es mas denso y por lo tanto cuenta con mejores propiedades como disolvente. De la misma manera, se observa que para presiones menores a 5 bar el  $\text{CO}_2$  pasa a formar una mezcla de gas solido, lo que dificultara incluso mas el proceso de extraccion. El proceso 4-5 sera una expansion isoentalpica, por lo que el estado de la sustancia en esta etapa se encuentra definido por los siguientes parametros:  $P_5 = 40\text{ bar}$ ,  $h_5 = h_4$ .

$$x_5 = \frac{h_5 - h_f}{h_g - h_f} = 0,574 \quad (\text{A12.4})$$

- Estado 6: En este estado el proceso consiste en calentar el  $\text{CO}_2$  para llevarlo al estado gaseoso y de esta manera reducir su densidad y consecuentemente su capacidad para disolver. El tener que dejar el  $\text{CO}_2$  como una mezcla vapor-líquido dificultaría el proceso de separación entre el  $\text{CO}_2$  y la oleorresina de paprika ya que en ese caso se debera buscar un proceso de separacion para el  $\text{CO}_2$  gaseoso y otro proceso de separacion para el  $\text{CO}_2$  lıquido. Se asegurara que el  $\text{CO}_2$  se mantenga en estado gaseoso en todo el proceso de separacion y que nada se licue, para esto se elevara la presion unos  $5\text{ }^\circ\text{C}$  mas del estado de vapor saturado. El proceso 5-6 consistira en un aumento de temperatura isobarica, por lo que el estado de la sustancia en esta etapa se encuentra definido por los siguientes parametros:  $P_6 = P_5 = 40\text{ bar}$ ,  $T_5 = 10\text{ }^\circ\text{C}$ , vapor sobrecalentado.

En la figura A12.5, se encuentran ubicados los 6 estados en el diagrama P-h para el  $\text{CO}_2$ .



Figura A12.5: Proceso termodinamico del proceso de extraccion supercrtica usando  $\text{CO}_2$ .

[CHEMICALOGIC CORPORATION, 1999]

En la tabla A12.2 se observan los 6 estados del proceso de extraccion supercrtica usando  $\text{CO}_2$ .

Tabla A12.2: Estados termodinámicos para el proceso de extracción supercrítica usando CO<sub>2</sub>.

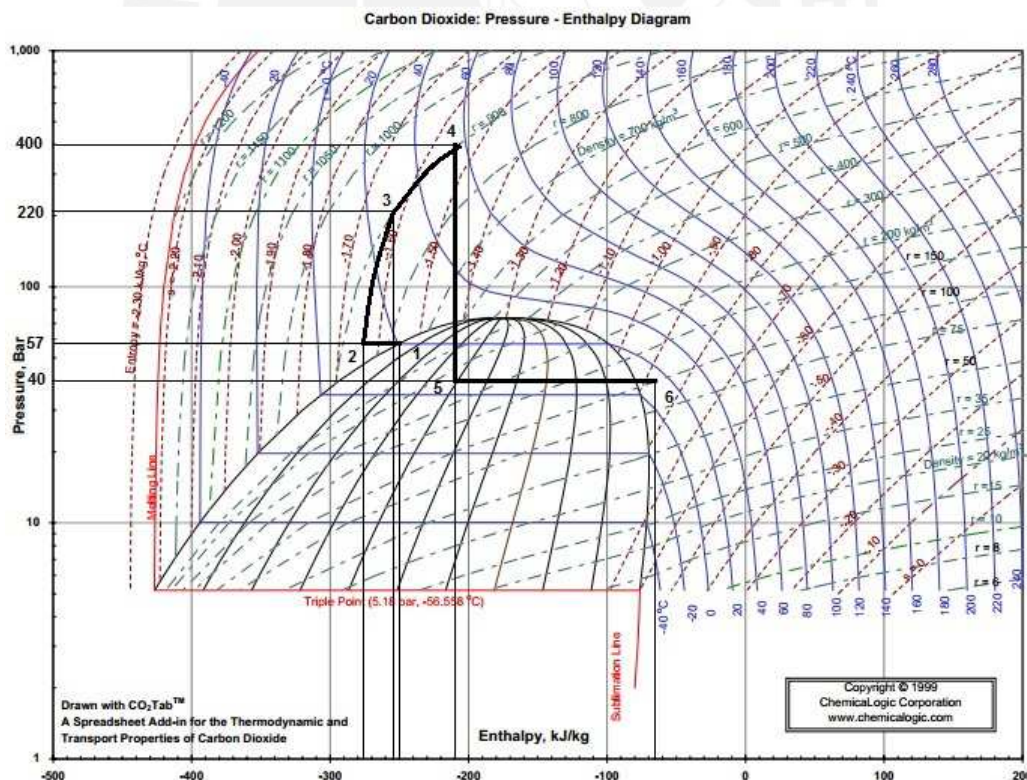
Estados Termodinámicos para la 2 <sup>o</sup> Opción de Proceso de Extracción de Oleorresina de Páprika usando CO <sub>2</sub> Supercrítico				
Estados	T (° C)	P (bar)	h (kJ/kg)	x
1	20	57	-250	Líquido Saturado
2	15	57	-285	Líquido Subenfriado
3	30	220	-260	Líquido Subenfriado
4	55	400	-210	Fluido Supercrítico
5	5	40	-210	39.53%
6	10	40	-10	Vapor Sobrecalentado

Esta opción tiene la ventaja que se puede aprovechar el recipiente de extracción que está diseñado para soportar presiones de hasta 400 bar, para de esta manera al aumentar la temperatura en el proceso de 3-4, el volumen del CO<sub>2</sub> se mantenga constante, lo que ocasionará que la presión aumente, gracias a esto, pasamos de requerir una bomba que comprima hasta 400 bar a una que comprima hasta 220 bar y dejamos de necesitar un intercambiador que caliente a 400 bar. Por estos motivos se optará por la segunda opción para diseñar la planta piloto de extracción de oleorresina de páprika.