

ANEXO 2: LIMPIADOR NEUMÁTICO GRANOS DE G. RYAN

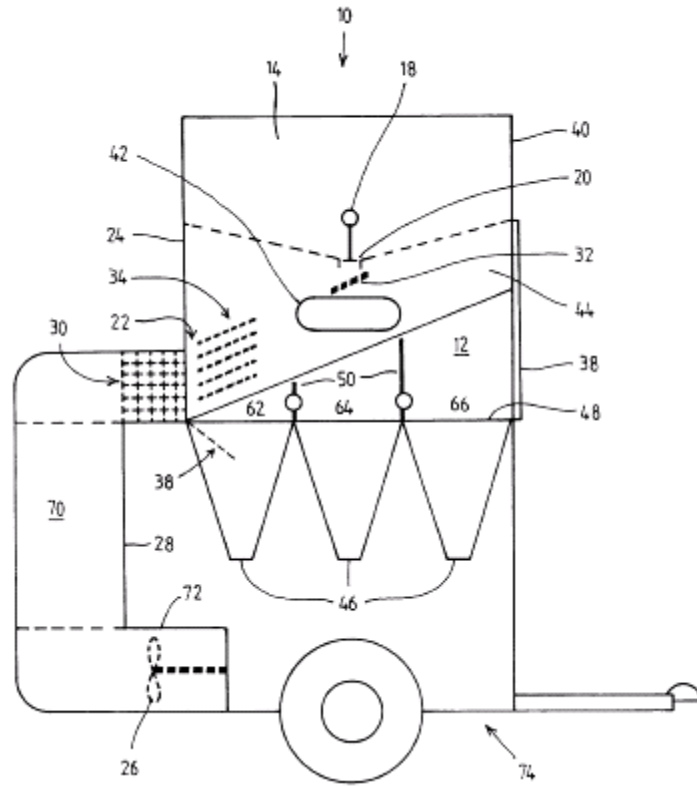

ANEXO 4: SEPARADOR DE MATERIAL GRANULAR DE GILES & CLARKE

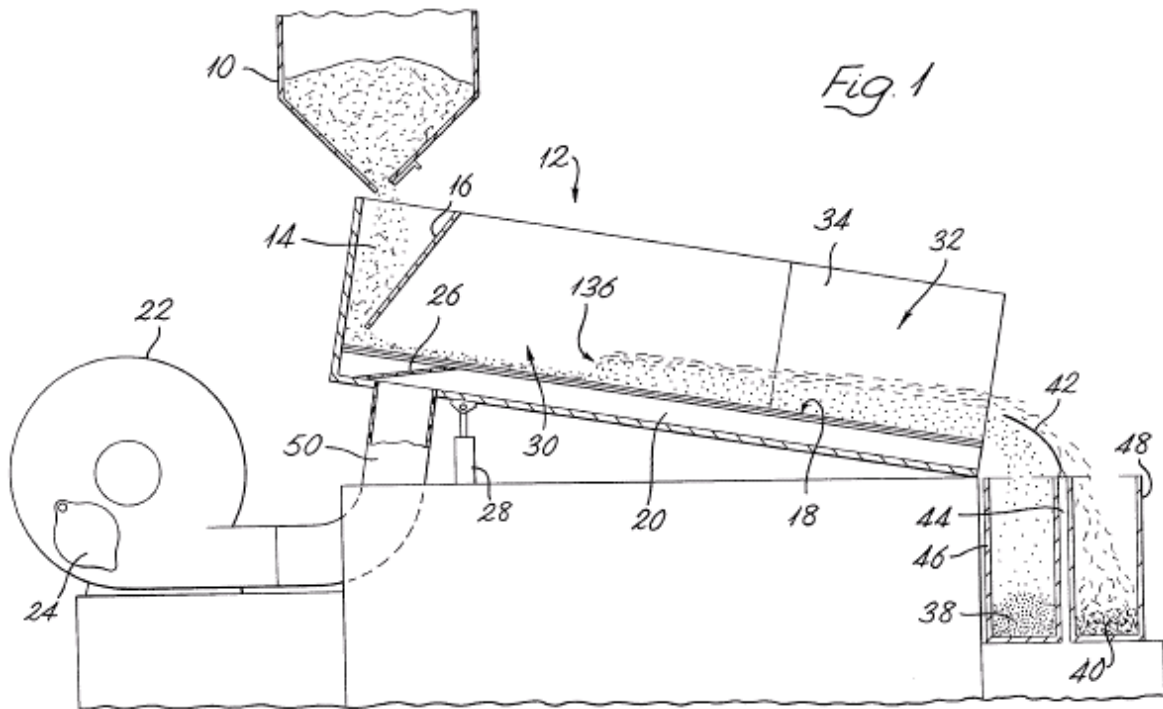

ANEXO 5: DISPOSITIVO PARA SEPARAR Y CLASIFICAR

MATERIAL DE GRANO GRUESO DE

K. STEIER

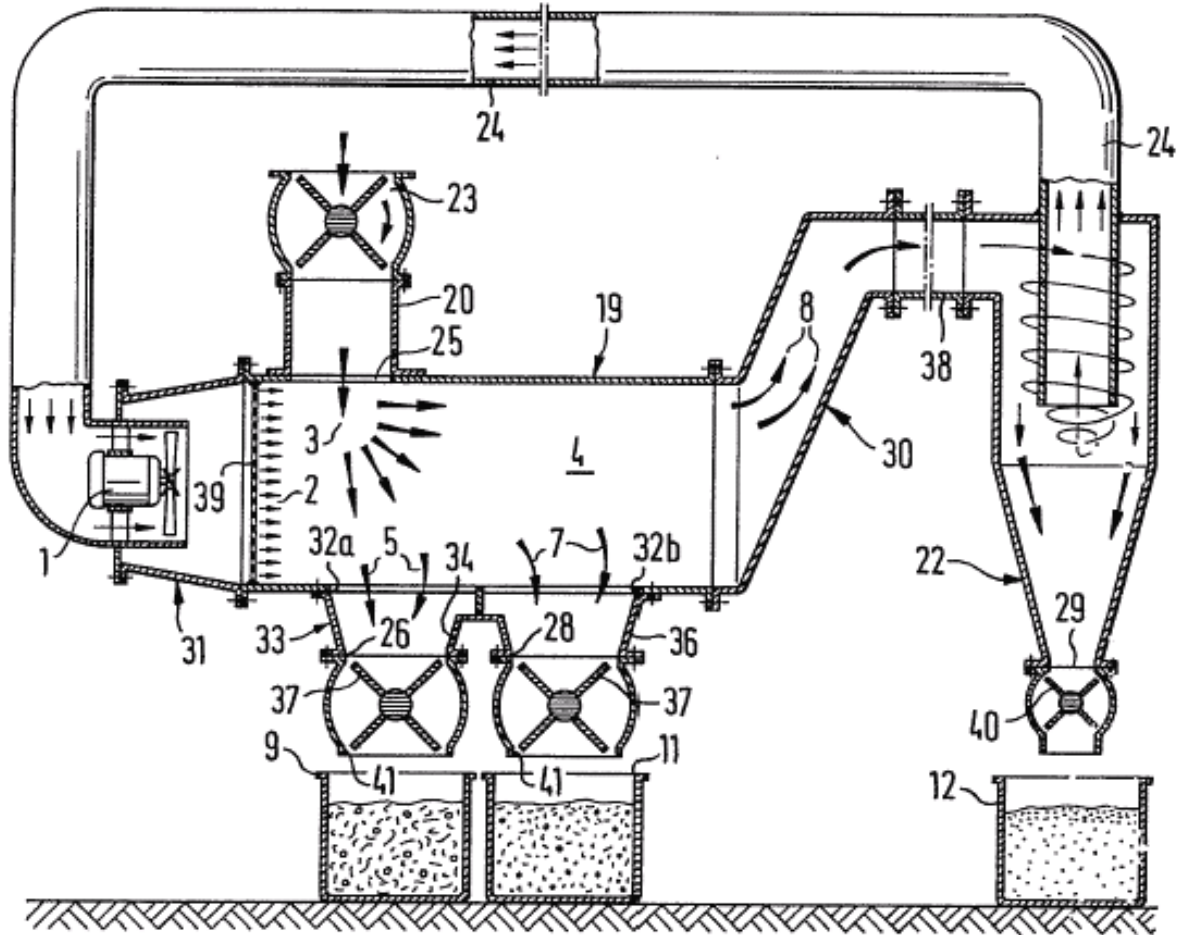

ANEXO 9: DIAGRAMA DE CORDIER

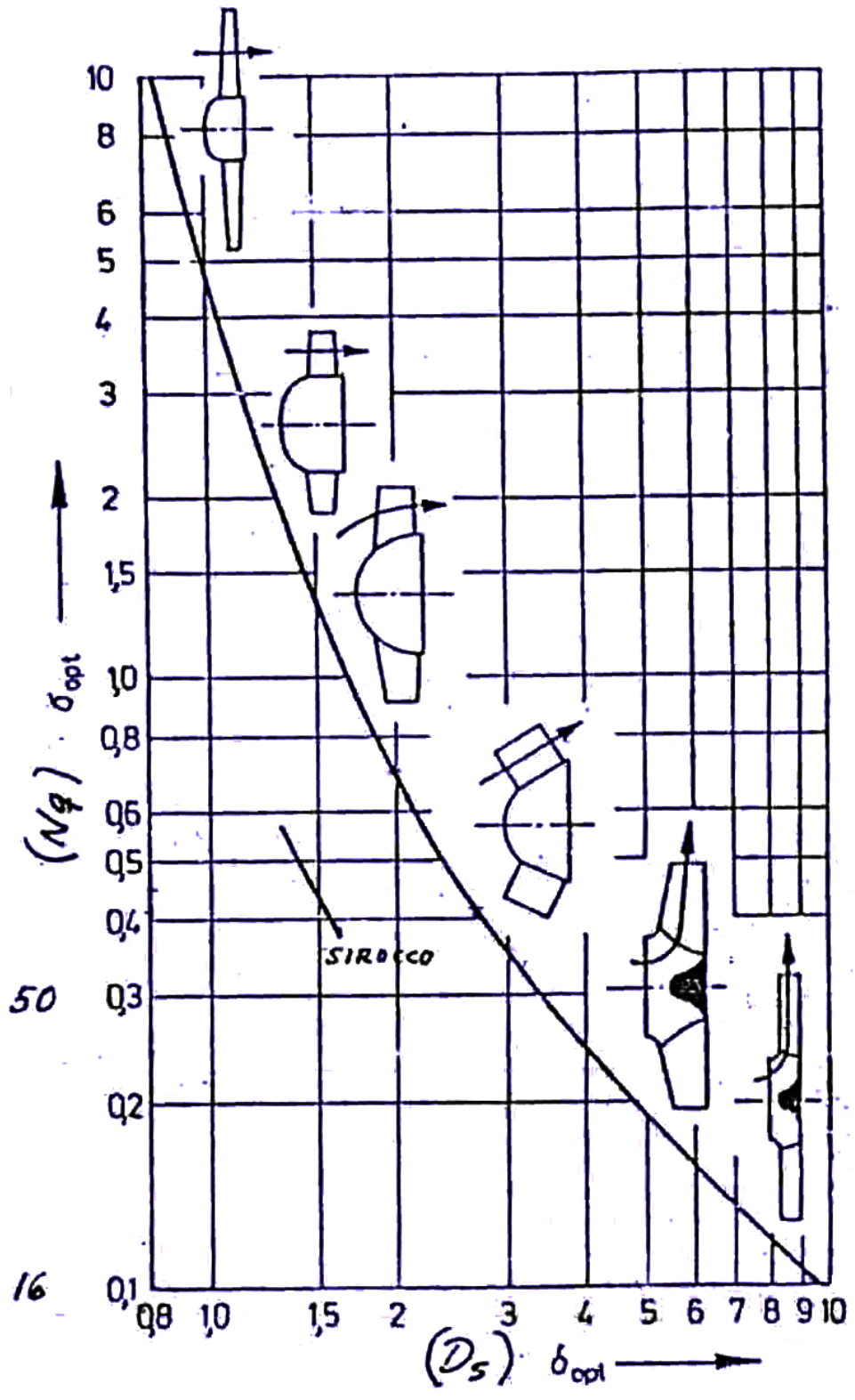

ANEXO 10: DIÁMETRO EQUIVALENTE PARA DUCTOS RECTANGULARES. [7]

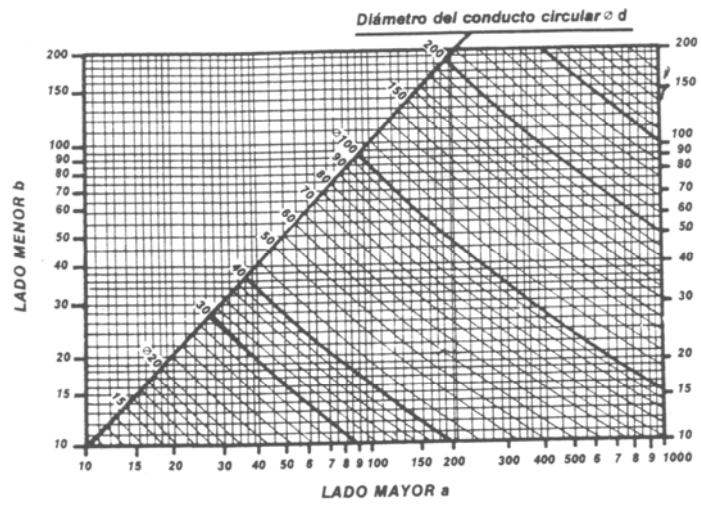

ANEXO 11: PÉRDIDAS EN TUBERÍAS EN mm/m. [7]

