

PONTIFICIA UNIVERSIDAD CATÓLICA DEL PERÚ
ESCUELA DE POSGRADO



**Entrepreneurial Leadership, Work Engagement, and Innovative Work
Behavior: The Moderating Role of Gender**

**TESIS PARA OBTENER EL GRADO DE DOCTOR EN
ADMINISTRACIÓN ESTRATÉGICA DE EMPRESAS**

PRESENTADA POR

Nory Analidhia, Pinela Morán
Pasaporte: 0918751678 – ECUADOR

ASESOR

Dr. Rubén, Guevara Moncada
DNI: 48642063 – PERU
ORCID: <https://orcid.org/0000-0002-4795-2557>

JURADO

Dr. Rubén, Guevara Moncada
Dr. Jaime Eduardo, Rivera Camino
Dr. Iván Manuel, De La Vega Hernández
Dr. Luciano, Barcellos de Paula
Santiago de Surco, mayo 2022



Dedication

I dedicate this research work to the Life of my soul, Alejandro and Adrian, who are the center of my being, who inspire my days, and have been fundamental, my strength and support, to achieve this goal. Beloved sons may this achievement be for you a benchmark of perseverance and discipline to fulfill your dreams and life purposes.

I also dedicate it to my parents, Pablo Pinela and Graciela Morán, for training me in essential values during my life, and for always being with me as motivators to keep going. Mother, you are undoubtedly my example of discipline and effort to achieve every goal.



Acknowledgements

To God, for the qualities he gave me and for allowing me to manage them correctly and with humbleness.

My permanent gratitude to my advisor, Dr. Rubén Guevara, for sharing with me his knowledge and for guiding me during my doctoral training process.

A special acknowledgement to the Econ. Alberto Dahik Garzozi, for his guidance and support to not quit in those moments when I faced complex situations in this hard process.

I thank Santiago Leal and Mary Armijos, unconditional friends, who shared their experiences as researchers with me, learning from them allowed me to enrich my study.

My gratitude to the authorities of the ECOTEC University, for believing in my work and sponsoring my doctoral training. It is an honor to be part of this institution that works to transform education in my country.

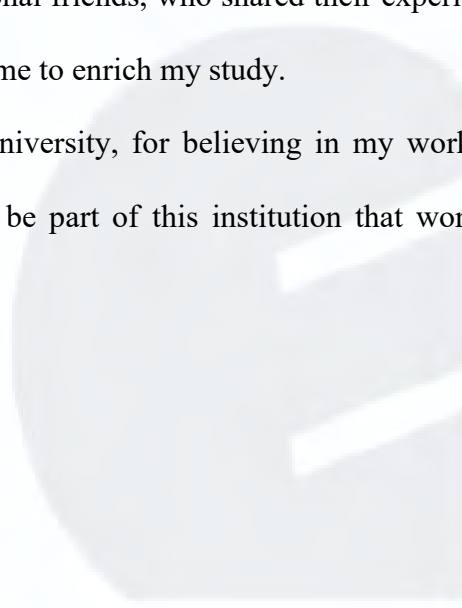
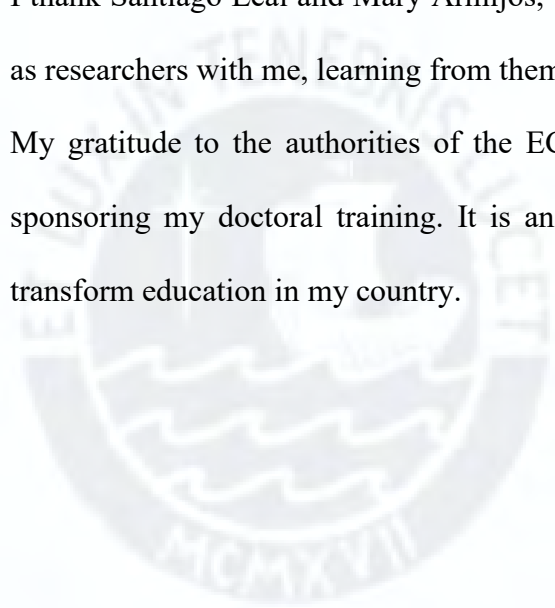

Abstract

The purpose of this research was to carry out an empirical study to analyze the mediating effect of work engagement on the relationship between entrepreneurial leadership and innovative work behavior in medium-sized companies. Additionally, this work evaluated the moderation role of gender in this relationship. A covariance-based structural equation model (CB-SEM) with the maximum likelihood estimation method was used to evaluate the proposed theoretical model. CB-SEM was chosen instead of structural equation modeling based on partial least squares (PLS-SEM), since this study has an explanatory and confirmatory approach based on theory. The population consisted of 526 medium-sized firms registered in the Database of the Superintendencia de Compañías, Valores y Seguros in Ecuador, taken from a universe of 14,432 medium-size firms from the manufacturing sector that operate in the cities of Guayaquil and Quito, the cities with the highest concentration of jobs in Ecuador. The random sample consisted of 312 valid surveys from employees that work at medium-sized manufacturing firms from Guayaquil and Quito in Ecuador. The findings revealed that entrepreneurial leadership has a significant and positive effect on innovative work behavior. In the same way, the study proved that work engagement mediates that relationship and that gender moderates it. Therefore, this study contributed with a new structural model linking entrepreneurial leadership with innovative work behavior, considering work engagement as mediator and gender as moderator, which has theoretical and practical implications.

Keywords: Entrepreneurial leadership, work engagement, innovative work behavior, gender

Resumen Ejecutivo

El propósito de esta investigación fue realizar un estudio empírico para analizar el efecto mediador del compromiso laboral sobre la relación entre el liderazgo emprendedor y el comportamiento innovador en el trabajo. Adicionalmente, este trabajo evalúa la moderación del género en esta relación. Se estima un modelo de ecuación estructural basado en covarianza (CB-SEM) con el método de estimación de máxima verosimilitud para evaluar el modelo teórico propuesto. Se eligió CB-SEM en lugar del modelo de ecuaciones estructurales basado en mínimos cuadrados parciales (PLS-SEM) ya que este estudio tiene un enfoque explicativo y confirmatorio basado en la teoría. Este estudio recopiló 312 encuestas válidas de empleados que trabajan en empresas manufactureras medianas de Guayaquil y Quito en Ecuador. Del universo de medianas empresas registradas en la Base de Datos de la Superintendencia de Compañías, Valores y Seguros del Ecuador (14.432), se seleccionaron las del sector manufacturero (526) que operan en Guayaquil y Quito por ser las ciudades con mayor concentración de empleos en el Ecuador. Los hallazgos revelan que el liderazgo emprendedor tiene un efecto positivo significativo en el comportamiento laboral innovador. Del mismo modo, el estudio prueba que el compromiso laboral media esa relación y el género la modera. Por lo tanto, este estudio contribuye con un nuevo modelo que vincula el liderazgo emprendedor con el comportamiento laboral innovador, considerando el compromiso laboral como mediador y el género como moderador, lo cual tiene implicaciones teóricas y prácticas.

Palabras clave: liderazgo emprendedor, compromiso laboral, comportamiento innovador en el trabajo, género

Table of Contents

Introduction.....	1
Chapter I: The Research Article	4
Chapter II. Conclusions and Recommendations.....	28
Conclusions	28
Implications	29
Recommendations.....	30
References.....	32
Appendix A: Acceptance letter of the research article	36

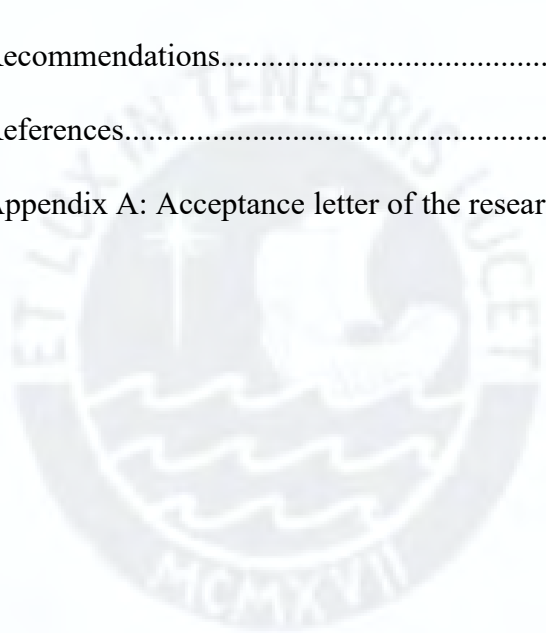

Introduction

This thesis is structured in two Chapters. The first Chapter presents the research paper accepted for publication, which is required to complete the degree of Doctor en Administración Estratégica de Empresas granted by the Pontificia Universidad Católica del Perú through its graduate school in business management, CENTRUM PUCP. The second Chapter includes the main conclusions and recommendations of the thesis. Therefore, Chapter 1 of this thesis includes the research paper entitled “Entrepreneurial Leadership, Work Engagement, and Innovative Work Behavior: The Moderating Role of Gender”, which was accepted for publication by the *International Journal of Economics and Business Administration* on May 11th, 2022 (see Appendix A). This journal is part of the Scopus database, in quartile Q2.

This study is motivated by the empirical findings in the scientific literature that show a positive relationship between entrepreneurial leadership and innovative work behavior (Newman et al., 2017), however, there are still few studies that explore this specific relationship (Bagheri, 2017). In the same way, authors such as Amor et al. (2019) and Leal et al., (2021), show a positive relationship between different types of leadership and work engagement, yet few studies examine the relationship between entrepreneurial leadership and work engagement. Additionally, Montani et al. (2019) found that work engagement has a positive impact on innovative work behavior, however, Agarwal (2014) mention that there is few empirical evidence of this effect. Therefore, authors such as Wang, Gao & Panaccio (2020) identified the need to carry out studies that address the effectiveness of management interventions or leadership style on the characteristics of employees to sustain their innovative work behavior in different firms and in different cultures. Additionally, Bagheri & Akbari (2018) recommend exploring the relationship between entrepreneurial leadership and

innovative work behavior to determine if gender affects this relationship in other organizations and countries.

Therefore, the purpose of this research was to evaluate the effect of entrepreneurial leadership on innovative work behavior and the mediation of work engagement in that relationship. Also, this research evaluates the moderation of gender in this relationship.

From a conceptual framework based on the literature review for the design of a theoretical framework of the conceptual model of this research, the main research question proposed was if there is a mediating effect of work engagement in the relationship between entrepreneurial leadership and innovative work behavior. For this analysis, the following hypotheses were proposed:

H1: Entrepreneurial leadership has a positive impact on work engagement.

H2: Entrepreneurial leadership has a positive impact on innovative work behavior.

H3: Work engagement has a positive impact on innovative work behavior.

H4: Work engagement has a mediating effect on the relationship between entrepreneurial leadership and innovative work behavior.

H5: Gender has a moderating effect on the relationship between entrepreneurial leadership and innovative work behavior.

The scales used for the questionnaire are the entrepreneurial leadership scale developed by Renko et al. (2015); the scale was translated into Spanish and to verify the conceptual equivalence of the translated scale, this means, the original meaning of the questions, a back-translation was made from Spanish to English (Cunningham et al., 2019). It was also used the Schaufeli & Bakker (2003) work engagement scale, which was already translated into several languages, including Spanish. And the innovative work behavior scale developed by Janssen (2000), recently translated into Spanish by Salessi (2021).

After reporting the evidence of construct validity for the measurement model, it was evaluated the equivalent interpretation of the constructs by workers from Guayaquil and Quito (Horn, 1991; Byrne, 2008). Multigroup analysis was used under the factor invariance approach in order to test whether there are similarities and differences (Hair, Babin, Anderson, & Black, 2018). As a result, it is verified that comparisons can be made with the mean scores of groups (Guayaquil and Quito) without worrying that the differences are associated with the different measurement properties between the two groups.

The main findings of this research showed that the proposed hypotheses are statistically significant. It was found that there is a significant positive relationship between entrepreneurial leadership and work engagement, which covers the empirical gap of these two constructs that was identified in the literature review of this study. Additionally, the study proves that gender moderates the relationship between entrepreneurial leadership and innovative work behavior. The impact was found to be stronger in women (0.511) compared to men (0.350).

This research is the first to empirically evaluate the mediating effect of work engagement on the relationship between entrepreneurial leadership and innovative work behavior; the empirical knowledge gap is addressed, analyzing the effects between the mentioned latent variables and gender, as a moderating variable within that relationship. Furthermore, this research contributes with results that can be taken as a guide for the management of firms. The adequate implementation of entrepreneurial leadership and the increase of work engagement could lead to innovative work behavior, which in turn can improve the performance of firms.

Chapter I: The Research Article

The research article “Entrepreneurial Leadership, Work Engagement, and Innovative Work Behavior: The Moderating Role of Gender” was accepted for publication on May 11th, 2022 in the *International Journal of Economics and Business Administration*, with ISSN 2241-4754, and indexed at the Scopus database in quartile 2 (Q2).

Entrepreneurial Leadership, Work Engagement, and Innovative Work Behavior: The Moderating Role of Gender

Abstract:

Purpose: This research examines the effect of entrepreneurial leadership on innovative work behavior and the mediation of work engagement in that relationship. Additionally, it evaluates the moderation of gender in this relationship.

Design/Methodology/Approach: We use data from medium-sized companies in Guayaquil and Quito in Ecuador. Through the use of a structural equation model, we analyze the mediating effect of work engagement in the relationship between entrepreneurial leadership and innovative behavior and the moderating role of gender.

Findings: The results show that entrepreneurial leadership has a significant positive impact on innovative behavior. Likewise, we find evidence for a significant mediation effect of work engagement in the relationship between entrepreneurial leadership and innovative work behavior. Additionally, gender moderation is verified, showing that the impact of entrepreneurial leadership on innovative behavior is stronger in women than in men.

Originality/value: This study proposes a new model considering three constructs—entrepreneurial leadership, work engagement, and innovative work behavior—which will serve future research on these topics. With these findings, we contribute new knowledge to both the scientific community and the management of firms.

Keywords: Entrepreneurial leadership, innovative work behavior, work engagement.

JEL codes: M12, J24, J81, M54

Paper type: Research article.

1. Introduction

In a competitive and changing business world, innovation and creativity are critical factors for gaining a competitive advantage and achieving organizational sustainability (Cai et al., 2018; Chow, 2018).

For instance, entrepreneurial leadership is a strategic leadership style (Fontana and Musa, 2017) that can contribute to this competitive advantage. The leadership styles can improve work engagement of employees not only directly but also indirectly through increased job resources and decreased job

demands (Schaufeli, 2015; Schaufeli and Bakker, 2004). Therefore, entrepreneurial leadership has an impact on work engagement, which can, in turn, develop innovative work behavior (Bani-Melhem et al., 2018; Bogilović et al., 2020).

The purpose of this study is to determine the effect of entrepreneurial leadership on innovative work behavior and the mediation of work engagement in that relationship; we also estimate the moderation effect of gender. The scales used for the questionnaire are the entrepreneurial leadership scale developed by Renko et al. (2015), the Schaufeli and Bakker (2003) work engagement scale, and the innovative work behavior scale developed by Janssen (2000). The survey was carried out on medium-sized manufacturing firms from Quito and Guayaquil in Ecuador.

Few studies can be found in the literature on the three constructs entrepreneurial leadership, work engagement, and innovative work behavior. The contribution of this study considers the research needs concerning entrepreneurship (Anwar et al., 2021), entrepreneurial leadership (Bagheri, 2017; Bagheri and Akbari, 2018; Bagheri and Harrison, 2020), its relationship with sociodemographic characteristics (Bagheri and Akbari, 2018; Kimbu et al., 2021), work engagement (Agarwal, 2014; Agarwal et al., 2012; Ahmad and Gao, 2018; Amor et al., 2020; De-la-Calle-Durán and Rodríguez-Sánchez, 2021; Hakanen et al., 2021; Iqbal et al., 2022; Karatepe et al., 2020), innovative work behavior (Akbari et al., 2021; Akram et al., 2020; Bani-Melhem et al., 2018; Iqbal et al., 2022; Knezović and Drkić, 2020; Li et al., 2020; Saeed et al., 2018; Wang et al., 2020), and the mediation mechanisms between entrepreneurial leadership and innovative work behavior (Akbari et al., 2021; Li et al., 2020).

Therefore, this study addresses this empirical knowledge gap theoretically and empirically. It constructs a structural equation model linking the three latent variables mentioned above. The main findings show that these links are significant, contributing new knowledge for both the scientific community and the managers of firms.

2. Literature Review

2.1 Entrepreneurial Leadership

According to Darling et al. (2007), entrepreneurial leadership can be defined as the process of influencing organizations through leadership and direct participation in value creation. Renko et al. (2015) established that entrepreneurial leadership implies influencing and guiding the performance of group members toward the achievement of organizational goals that involve the recognition and exploitation of entrepreneurial opportunities. They developed and validated a scale called ENTRELEAD to measure employees' perception of the attitudes that identify an immediate manager

or team leader as an entrepreneurial leader. Moreover, Fontana and Musa (2017) defined entrepreneurial leadership as a leadership style that focuses on making heterogeneous talents in a firm work in a more creative and innovative way to respond to an uncertain business environment (innovation process) and create adequate strategies and novel results (innovation performance). Therefore, this type of leadership seeks to boost the creativity of employees, thus adjusting to the trends of the current century (Mehmood et al., 2021). Additionally, Liu et al. (2022) found that entrepreneurial leadership is related to the capacity of employees to improvise. Regarding small and medium-sized enterprises (SMEs), Nguyen et al. (2021) highlight the importance of entrepreneurial leadership because of its influence on business performance.

2.2 Innovative Work Behavior

The literature review showed that innovative work behavior begins with the work of Kanter (1988), who explained that the innovation process is carried out through four phases: the identification of problems and brainstorming solutions; the search for partnerships or sponsorships that allow companies to obtain the necessary power to materialize their ideas; the realization of the ideas, producing innovation; and the diffusion or adoption of the innovation. Janssen (2000) was the first to try to develop a multidimensional measure of innovative work behavior. He considered three behavioral tasks—idea generation, idea promotion, and idea realization—and concluded that their items would be better combined and used as a single additive scale. De Jong and Den Hartog (2008) confirmed the hypothetical relationships between innovative work behavior and participative leadership, distinguishing four forms of innovative work behavior that develop within the innovation process. Recently, Alheet et al. (2021) found that other type of leadership, transformational leadership, stimulates positively the innovative work behavior of employees. In addition, Afsar et al. (2021) studied various elements that could lead to an innovative work behavior, such as, cultural intelligence, engagement and interpersonal trust. The authors demonstrate that cultural intelligence does have an impact on innovative work behavior, and interpersonal trust and engagement act as partial mediators on that relationship. Furthermore, Wang et al. (2022) show how high-involvement work practices (empowerment of employees) impact the innovative work behavior. Similarly, Datta et al. (2021) demonstrate that human resource management practices can boost the talent of workers, hence increasing innovation at work.

2.3 Work Engagement

Kahn (1990) began studying work engagement based on the role theory of employees at work. He distinguished that, in engagement, people express themselves physically, cognitively, and emotionally during role tasks, the components of engagement being the physical, cognitive, and emotional factors.

Furthermore, Schaufeli et al. (2002) conceptualized work engagement as a positive, satisfying, work-related state of mind composed of three elements—vigor, dedication, and absorption—and developed a scale for its measurement based on them: (a) vigor is distinguished by high energy levels and mental resilience, the willingness to invest effort in work, and persistence even in the face of difficulties; (b) dedication denotes a sense of importance, enthusiasm, inspiration, pride, and challenge; and (c) absorption is defined in terms of psychological identification with the job. Regarding these elements, Neuber et al. (2022) showed that the three elements of engagement have a positive relationship with performance at work, and only vigor and dedication show a negative relationship with absenteeism. Among the factors that can improve the work engagement, Garg et al. (2017) identify that labor satisfaction has a positive impact on engagement. By other side, Reina-Tamayo et al. (2018) found that that the joint effect of job demands that challenge labor or personal resources leads to higher levels of work engagement. Whereas the factors that could diminish work engagement are the job demands that hinder the labor or personal resources (Reina-Tamayo et al., 2018) and high levels of work stress (Gómez-Salgado et al., 2021).

2.4 Entrepreneurial Leadership and Innovative Work Behavior

The relationship between the constructs entrepreneurial leadership and innovative work behavior has been explored by a few researchers. In China, it has been shown that leaders who adopt entrepreneurial behaviors, such as identifying and exploiting opportunities, are more likely to encourage innovative behavior among employees (Newman et al., 2018). In the same country, Li et al. (2020) found a positive and significant effect of entrepreneurial leadership on the innovative work behavior of employees. In other contexts, research performed by Newman et al. (2017) on a population of employees and entrepreneurs of small social enterprises in Australia, Canada, and the United Kingdom confirmed that entrepreneurial leadership is positively related to the innovative behavior of followers. In high-tech companies, entrepreneurial leadership has been found to foster innovative employee behavior through the mediating mechanisms of creative self-efficacy and passion for invention (Bagheri and Harrison, 2020). In small and medium-sized companies, findings have indicated that entrepreneurial leadership exerts a significant and positive impact on the innovative work behavior of employees (Akbari et al., 2021).

2.5 Entrepreneurial Leadership and Work Engagement

The literature review on the link between entrepreneurial leadership and work engagement allows us to identify studies that have tested hypotheses between different leadership styles and work engagement. For instance, Amor et al. (2020) found that transformational leadership is a significant predictor of work engagement. Other studies have confirmed, through their hypotheses, the positive

and significant effect between authentic leadership and work engagement (Giallonardo et al., 2010; Leal et al., 2021; Oh et al., 2018), between ethical leadership and work engagement (Ahmad and Gao, 2018; Asif et al., 2019), between servant leadership and work engagement (Cai et al., 2018), and between entrepreneurial leadership and organizational engagement, the latter being different from work engagement. Rahmadani and Schaufeli (2022) confirm the importance of leadership on engagement; they found that transformational and engaging leadership have a positive relationship with work engagement. Schaufeli (2021) asserts that engaging leadership relates to the different mechanisms (such as motivation) that a leader can exert on employees so that they commit to their work.

2.6 Work Engagement and Innovative Work Behavior

Different researchers have linked the constructs work engagement and innovative work behavior. Agarwal et al. (2012) showed that, in service sector firms from India, work engagement is positively correlated with innovative work behavior. In the same way, in manufacturing and pharmaceutical firms, findings have revealed that job engagement significantly influences the innovative work behavior of employees (Agarwal, 2014). In the banking sector, Garg and Dhar (2017) found that the exchange between the leader and the employee has a positive effect on the innovative work behavior, work engagement being a mediator variable on this relationship. Moreover, Park et al. (2014) studied the manufacturing sector in Korea, concluding that work engagement significantly influences the innovative work behavior of employees. Another study conducted with a variety of US and Canadian employees from the architecture, design, communication, marketing, and technology industries showed that work engagement is positively related to innovative work behavior (Montani et al., 2019). Additionally, Kwon and Kim (2020) illustrate, in an integrative literature review, that employees that experience engagement at work, tend to behave innovatively at work, as they react positively to challenges. Similarly, Mulligan et al. (2021), prove that engagement is one of the mechanisms towards innovation at work.

2.7 Entrepreneurial Leadership, Work Engagement and Innovative Work Behavior

An entrepreneurial leader takes risks, influences and guides the performance of employees (Renko et al., 2015), and encourages them to understand the needs of the organization by working creatively and innovatively (Fontana and Musa, 2017). This type of leader also motivates employees to be committed to their work, inspires positive emotions, conciliation, trust, and communication, stimulates work engagement (De-la-Calle-Durán and Rodríguez-Sánchez, 2021), and demonstrates passion for generating new ideas (Bagheri and Harrison, 2020).

Empirical results have revealed that the behavior of entrepreneurial leaders produces a positive effect on innovative work behavior (Akbari et al., 2021; Bagheri and Harrison, 2020) and that work engagement exerts a positive impact on innovative work behavior (Agarwal, 2014; Garg and Dhar, 2017; Montani et al., 2019). These arguments and findings issued by academics and researchers provide high-quality information inferring that there is a relationship between entrepreneurial leadership, work engagement, and innovative work behavior. However, the literature review highlights an empirical gap regarding the linkage of these three constructs.

2.7.1 Gender as a Moderation Variable

The use of control variables is relevant because it allows researchers to consider the effect of sociodemographic characteristics on the variables of interest in a study (Bernerth and Aguinis, 2015). This research addresses entrepreneurial leadership as a construct that is part of entrepreneurship, which can be determined by the personal characteristics of an individual, including sociodemographic traits such as gender, age, and educational background (Ge et al., 2019). For instance, Hernaus et al. (2019) found that gender is a relevant predictor of innovative work behavior.

Therefore, in this research, we considered the inclusion of sociodemographic variables since other authors also use these variables in their study of entrepreneurial leadership (Cai et al., 2019; Iqbal et al., 2022; Kimbu et al., 2021; Li et al., 2020; Mehmood et al., 2021), work engagement (Amor et al., 2020; Garg and Dhar, 2017; Hakanen et al., 2021; Iqbal et al., 2022), and innovative work behavior (Knezović and Drkić, 2020; Li et al., 2020; Newman et al., 2017).

2.7.2 Research Hypotheses

Based on the literature review, we proposed the following research hypotheses:

H1: Entrepreneurial leadership has a positive impact on work engagement.

H2: Entrepreneurial leadership has a positive impact on innovative work behavior.

H3: Work engagement has a positive impact on innovative work behavior.

H4: Work engagement has a mediating effect on the relationship between entrepreneurial leadership and innovative work behavior.

H5: Gender has a moderating effect on the relationship between entrepreneurial leadership and innovative work behavior.

In covariance-based structural equation modeling (CB-SEM), hypotheses are represented by trajectories among the constructs. The hypothetical conceptual model presented in Figure 1 describes the relationship between the latent constructs entrepreneurial leadership (EL), work engagement (WE), and innovative work behavior (IWB).

Figure 1. Conceptual model

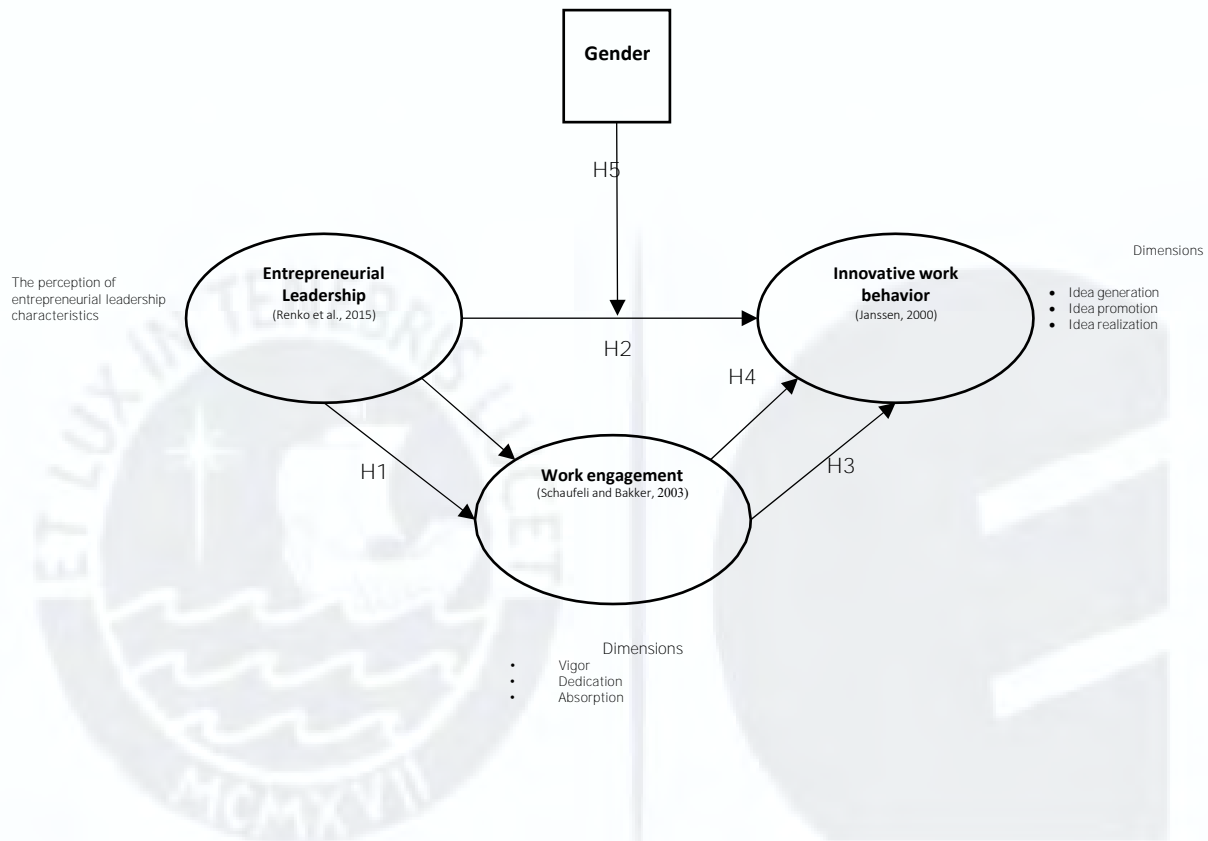

3. Methodology and Data

In Ecuador, the National Institute of Statistics and Censuses (INEC in Spanish), based on information from the Andean Community of Nations (CAN in Spanish), classifies firms according to their size, using the number of employees registered by the Ecuadorian Institute of Social Security (IESS in Spanish). A medium-sized firm has between 50 and 199 employees (Camino-Mogro and Avilés-Terán, 2019) and an annual income between USD\$1,000,000.01 and USD\$5,000,000.00, as specified by the Organic Code of Production, Commerce and Investments of Ecuador.

Moreover, according to the 2021 Annual Bulletin of the Central Bank of Ecuador, and the Manufacturing Industry Study of the Superintendence of Companies, the manufacturing sector makes a large contribution to the gross domestic product of Ecuador (GDP), being one of the most stable sectors with a high number of jobs in the country. Therefore, from the universe of medium-sized firms

registered in the Database of the Superintendency of Companies of Ecuador (a total of 14,432 companies), we selected the firms from the manufacturing sector (526 firms) that function in Guayaquil and Quito. We only considered these two cities because they are the main cities in the country with the highest concentration of jobs in Ecuador (62%).

Afterwards, we sent an email, explaining the data collection process, to the managers of the firms that had updated their information in the database, obtaining a response rate of 9%. This low level of willingness to participate in the study can be related to confidentiality issues, according to Iqbal et al. (2022) and Shujahat et al. (2018). We obtained the sample using a simple random probabilistic sampling process, in which each company had the same probability of participating (Verma and Verma, 2020).

Finally, we obtained 312 valid questionnaires from the 394 responses; we did not consider incomplete questionnaires as missing data would compromise the analyses. Authors such as Hair et al. (2018) and Kline (2016) considered that a sample size greater than 250 is sufficient in CB-SEM to minimize the impact of sampling error. In this sense, the sample of the present study is considered adequate to carry out the analysis and verify the research hypotheses (Gomer et al., 2019).

3.1 Measures

We used the scale of Renko et al. (2015), the Entrepreneurial Leadership (ENTRELEAD) Scale, for the measurement of the entrepreneurial leadership variable. According to the authors, it reflects the perceptions of the entrepreneurial leadership characteristics of a firm's leaders. The scale was translated into Spanish and to verify the conceptual equivalence of the translated scale, this means, the original meaning of the questions, we made a back-translation from Spanish to English (Cunningham et al., 2019). The instrument consists of eight items, for example "My manager often comes up with radical improvement ideas for the products/services we are selling." The questionnaire uses a Likert frequency scale from 1 to 5: 1 ("totally disagree"), 2 ("disagree"), 3 ("neither agree nor disagree"), 4 ("agree"), and 5 ("totally agree").

For the work engagement construct, we used the work engagement scale or the Utrecht Work Engagement Scale (UWES) developed by Schaufeli and Bakker (2003), translated into several languages, including Spanish. The 17-item questionnaire considers the feelings of people at work, and assesses three aspects: (1) vigor (six items, for example "At my job, I feel strong and vigorous"), (2) dedication (five items, for example "I am proud of the work that I do"), and (3) absorption (six items, for example "I am immersed in my work"). The questionnaire also uses a Likert frequency scale from 1 to 5: 1 ("totally disagree"), 2 ("disagree"), 3 ("neither agree nor disagree"), 4 ("agree"), and 5

(“totally agree”).

To measure innovative work behavior, we used Janssen’s (2000) scale, recently translated into Spanish by Salessi (2021). This instrument, that is composed of 9 items, assesses three dimensions: (1) idea generation (three items, for example “I generate original solutions to labor problems”), (2) idea promotion (three items, for example “I make important organizational members enthusiastic about innovative ideas”), and (3) idea realization (three items, for example “I introduce innovative ideas into the work environment in a systematic way”). The questionnaire uses a Likert frequency scale from 1 to 5: 1 (“totally disagree”), 2 (“disagree”), 3 (“neither agree nor disagree”), 4 (“agree”), and 5 (“totally agree”).

Besides the scales used for the questionnaire, we included the data corresponding to the description of the sample, such as the socio-demographic control variables gender, age, and educational level. The first is used as a moderating variable.

3.2 Data Analysis

We analyzed the data in three stages, processing them with the statistical programs SPSS 26 (IBM Corp., 2019) and AMOS 26 (Arbuckle, 2019). First, we carried out a descriptive and inferential analysis. Second, we examined the psychometric properties of the measurement scales to obtain evidence of validity based on the internal structure of the instrument. For this procedure, the covariance-based structural equation model (CB-SEM) was used, and, to carry out the confirmatory factor analysis (CFA), we used the estimation method of maximum likelihood. From the results obtained, we evaluated the convergent and discriminant validity and the reliability (Ferrando et al., 2022). As the third stage, we used CB-SEM once more to evaluate the proposed theoretical model. We chose CB-SEM instead of structural equation modeling based on partial least squares (PLS-SEM) since this study adopted an explanatory and confirmatory approach based on theory (Hair, Babin, and Krey, 2017; Hair et al., 2017). Subsequently, the results are reported according to the reporting standards for non-experimental studies (Appelbaum et al., 2018).

4. Results

The study population consisted of 312 workers from manufacturing firms, of whom 57% ($n = 178$) are from Guayaquil and 43% (134) are from Quito. Most employees are male (61%), and 86% of them are between 18 and 45 years old. Moreover, 89% of the workers have not exceeded the level of secondary education.

4.1 Descriptive and Inferential Analysis of the Constructs

In Table 1, we display the descriptive statistics for the dimensions evaluated. There are no missing data, and, through the Mahalanobis distance, we could not detect any outliers that could bias the results (Byrne, 2016). A higher average score toward the superior options (agree) and moderate dispersion between the data can be observed. The skewness and kurtosis values are within the expected limit according to the criteria of Finney and DiStefano (2006), according to whom the maximum values allowed are ± 2 for skewness and ± 7 for kurtosis. Thus, the data exhibited a distribution within the limits of univariate normality.

Furthermore, the value of the coefficient of Mardia (1970), based on the asymmetry and kurtosis, is 15.9. Hence, we found evidence of the fulfillment of the assumption of multivariate normality since it is lower than the 224 suggested by Bollen (1989) based on the equation $p(p + 2)$, where p is the number of variables observed in the CB-SEM model. The correlations between the dimensions are below 0.9, demonstrating the absence of multicollinearity.

Table 1. Descriptive results for the dimensions of the constructs (N = 312)

Variables	1	2	3	4	5	6	7
1. Entrepreneurial leadership (EL)	-						
2. Vigor	0.300**	-					
3. Dedication	0.282**	0.614**	-				
4. Absorption	0.408**	0.678**	0.606**	-			
5. Idea generation (IG)	0.665**	0.383**	0.250**	0.431**	-		
6. Idea promotion (IP)	0.575**	0.395**	0.265**	0.453**	0.772**	-	
7. Idea realization (IR)	0.655**	0.410**	0.257**	0.457**	0.688**	0.718**	-
Arithmetic mean	3.54	3.09	3.06	3.25	3.17	2.74	3.28
Typical deviation	1.35	0.94	0.86	0.93	0.62	1.37	1.39
Asymmetry	-0.40	0.52	-0.09	0.22	-1.56	0.42	-0.65
Kurtosis	-1.20	-0.40	-0.54	-0.49	-1.52	-1.08	-0.95

Note: ** $p < 0.01$.

Table 2 contains the results of the evaluation of the models that represents the items of (1) entrepreneurial leadership, (2) work engagement, (3) innovative work behavior, and (4) the average of the items for the latent constructs entrepreneurial leadership, work engagement, and innovative work behavior. The comparative fit index (CFI) ≥ 0.90 is favorable evidence of model fit (Bentler, 1990; Hu and Bentler, 1999), which is accomplished in all the models evaluated. Regarding the root mean

square error of approximation (RMSEA) and the standardized root mean squared residual (SRMR), we also obtained favorable evidence for the four models (≤ 0.08) (MacCallum et al., 1996). Consequently, the four models show an adequate fit with the indices suggested by the literature.

Table 2. Fit indices for the measurement models

Measurement model	$\chi^2_{(gl)}$	p	CFI	RMSEA	SRMR
(1) Entrepreneurial leadership (EL)	86.15 (20)	$p < 0.000$	0.955	0.059	0.025
(2) Work engagement (WE)	195.25 (116)	$p < 0.000$	0.973	0.048	0.050
(3) Innovative work behavior (IWB)	30.15 (24)	$p < 0.000$	0.997	0.029	0.023
(4) EL + WE + IWB	160.76 (74)	$p < 0.000$	0.973	0.063	0.036

4.2 Validity and Reliability

Model 4 is the one that we consider to obtain the construct validity. We use the standardized factor loadings as input for convergent and discriminant validity and reliability estimation. Hair et al. (2018) suggested individual standardized factor loadings of ≥ 0.7 , a value of $\geq 50\%$ for the average variance extracted (AVE), and a minimum threshold of 0.7 for adequate reliability of the construct by means of Cronbach's alpha coefficient (α) and composite reliability (CR).

The standardized factor loadings for model 4 present values above 0.7. At the bottom of Table 4, the AVE of each latent construct exceeds the criterion of 0.5. Likewise, the reliability coefficients (CR and α) are all above 0.7, suggesting adequate internal consistency (Cho, 2016). These results support the evidence of convergent validity of the measurement model.

Regarding discriminant validity, in Table 3, we show the correlations between the latent constructs (model 4) in the lower diagonal and the squared correlations between those constructs in the upper part. According to Hair et al. (2018), to establish discriminant validity, the AVE estimates of each construct are compared with the squared correlations between constructs, which must be less than their associated AVE. In Table 3, all the AVE estimates are greater than their corresponding squared estimates. Thus, this result indicates that there are no problems with discriminant validity.

Furthermore, since there are no cross-loadings or correlated errors, there is almost no evidence against discriminant validity. Therefore, these findings prove the discriminant validity of the measurement model.

Table 3. Convergent and discriminant validity of the constructs

	1. EL	2. WE	3. IWB
1. Entrepreneurial leadership (EL)	-	0.28	0.58
2. Work engagement (WE)	0.53***	-	0.29
3. Innovative work behavior (IWB)	0.76***	0.54***	-
Average variance extracted (AVE)	60.2%	67.8%	89.4%
Composite reliability (CR)	0.82	0.76	0.86
Alpha (α)	0.79	0.73	0.81

Note: Values below the diagonal are estimates of correlations between constructs, and values above the diagonal are squared correlations.

*** $p < 0.001$.

4.3 Evaluation of the Proposed Model

In Figure 2, we show the structural equation model evaluated. To estimate the parameters of the structural model, obtain the fit indices, and undertake a review to assess whether the structural relationships (trajectories) are consistent with the theoretical expectations, we used CB-SEM and maximum likelihood as the estimation method.

The fit indices ($\chi^2 (74) = 160.76$; $\chi^2/df = 2.17$; $p < 0.001$; CFI = 0.973; RMSEA = 0.063; SRMR = 0.036) suggest that the model has an adequate fit. Thus, with these data, the results reflect the empirical evidence of the theoretical model.

Figure 2. Conceptual model of the factors that explain the mediation of work engagement in the relationship between entrepreneurial leadership and innovative work behavior

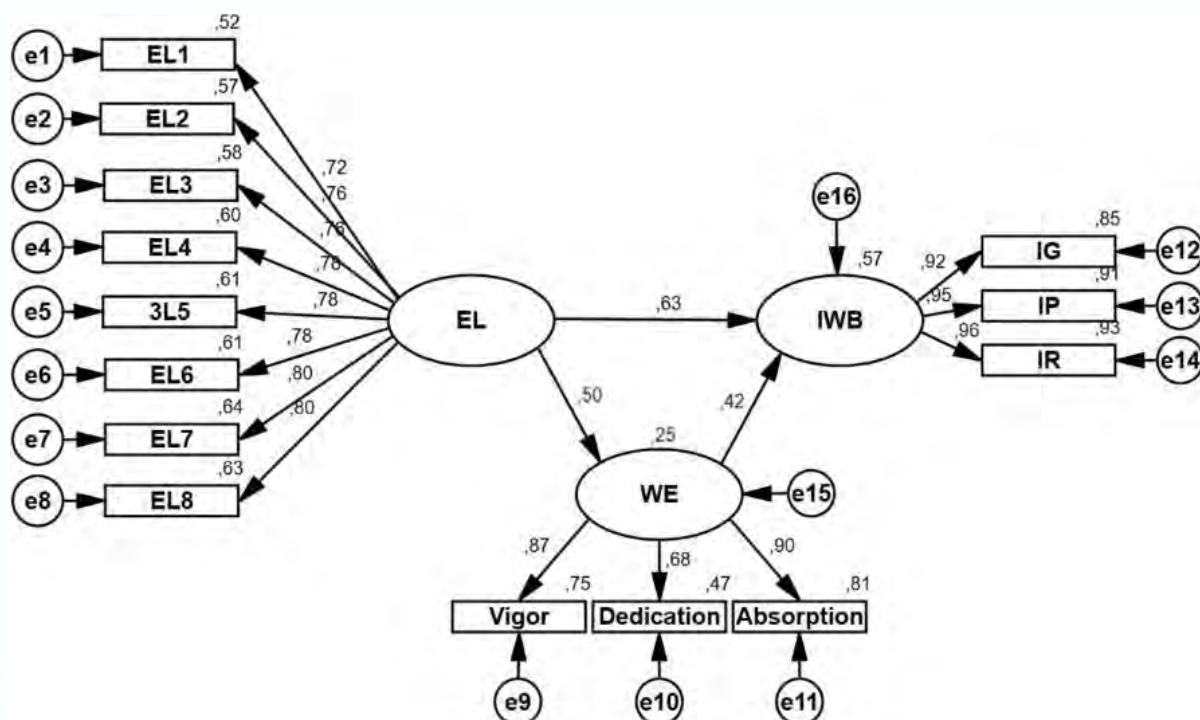

Note: Developed using IBM SPSS v26 and AMOS v26.

Table 4 shows the structural model results of the first three research hypotheses of the study. When examining the estimated standardized factor loadings for the structural relationships of the theoretical model, we can observe moderate values, which are statistically significant and in the expected direction. The explained variability (R^2) of innovative work behavior is 57%, and that of work engagement is 25%. In this sense, the three hypotheses are supported.

Table 4. Structural model test results

Hypothesized Relationships	Standardized Estimates	t-values	Hypothesis Supported
H1: Entrepreneurial leadership → work engagement	0.50	10.79	Supported
H2: Entrepreneurial leadership → innovative work behavior	0.63	14.84	Supported
H3: Work engagement → innovative work behavior	0.42	9.72	Supported
Squared multiple correlation (R^2):			
Work engagement	0.25		
Innovative work behavior	0.57		

4.3.1 Work Engagement Mediation

We decompose the direct and indirect effects to determine the magnitude of the mediation effect (Hair et al., 2018). Table 5 shows the mediation analysis, which reveals a statistically significant indirect effect of low magnitude in the expected direction of work engagement, therefore supporting H4. Additionally, we find that the direct effect of entrepreneurial leadership on innovative work behavior is statistically significant, supporting H2. Therefore, work engagement has a partial mediating effect on the relationship between entrepreneurial leadership and innovative work behavior.

Table 5. Bootstrap mediation test and 95% confidence interval

Hypothesized Relationships	Direct Effect	Indirect Effect	Confidence Interval		p	Hypothesis Supported
			Low	High		
H4: Entrepreneurial leadership → work engagement → innovative work behavior	0.628 (0.000)	0.229	0.149	0.309	0.004	Supported

Note: The values in the table represent standardized effects.

4.3.2 Gender Moderation

The moderation of gender in the relationship between entrepreneurial leadership and innovative work behavior was examined using multigroup analysis (Byrne, 2008). The theory suggests a gender difference in this relationship, so the magnitude of the relationship would be greater for women than for men. Previously, an invariance analysis was performed according to gender, guaranteeing metric invariance. This was enough to assess the moderation of gender in entrepreneurial leadership's effect on innovative work behavior.

Table 6 presents the results of the moderation. The second column reports the structural model without restrictions and the third column the restricted model. Both models show acceptable fit indices (CFI and RMSEA). The chi-square difference $\Delta\chi^2$ between the models is statistically significant, suggesting that the restricted model has a lower fit. This result suggests that gender moderates the relationship between entrepreneurial leadership and innovative work behavior.

Table 6. Gender moderation test between entrepreneurial leadership and innovative work behavior

Model Features	Unconstrained Group Model	Restricted Group Model	Difference of the Models
Model fit (gender)			
χ^2 (gl)	282,029 (149)	275,882 (148)	6,147 (1); p = 0.013
IFC	0.943	0.932	-
RMSEA	0.055	0.064	-

Note: Estimation values are standardized.

In Table 7, we show that the standardized loadings for the model without restrictions are statistically significant in both groups. Indeed, the impact is slightly higher for women than for men. Thus, empirical support is found for H5.

Table 7. Gender moderation between entrepreneurial leadership and innovative work behavior

Hypothesized Relationships	Standardized Estimates	t-Values	Hypothesis Supported
H5: Entrepreneurial leadership → innovative work behavior	0.511 (female) 0.350 (male)	4,242 5,507	Supported

5. Discussion and conclusions

The findings of this research demonstrate that the proposed hypotheses are statistically significant. We found a significant positive relationship between entrepreneurial leadership and work engagement, which fills the empirical gap that was identified in the literature review of this study. Therefore, hypothesis 1 (H1) is accepted; this is supported by the previous research carried out by Cai et al. (2018), Leal et al. (2021), and Lisbona et al. (2018) on the different types of leadership and work engagement. The results also reveal that the positive relationship between entrepreneurial leadership and innovative behavior is significant, validating hypothesis 2 (H2). Similar results were obtained by Li et al. (2020) and Newman et al. (2018) in China, Newman et al. (2017) in Australia, Canada, and the United Kingdom, and Bagheri and Akbari (2018) in Iran.

Likewise, there is a positive impact of work engagement on innovative work behavior, which leads to the acceptance of hypothesis 3 (H3). This finding is consistent with other research that has presented the same result, showing that committed employees experience emotions such as happiness, joy, interest, and enthusiasm in their work, which constitute the motivational basis on which to promote innovative work behavior (Agarwal et al., 2012). Additionally, engaged employees may experience a

better relationship with their supervisors, ensuring greater support for new ideas (Garg and Dhar, 2017; Montani et al., 2019).

Regarding mediation, hypothesis 4 (H4) is accepted; we verified that work engagement indeed has a mediating effect on the relationship between entrepreneurial leadership and innovative work behavior. Empirical results have shown separately that entrepreneurial leadership has a positive effect on innovative work behavior (Li et al., 2020) and that work engagement produces a positive effect on innovative work behavior (Agarwal, 2014; Garg and Dhar, 2017). The link between the three constructs has not previously been tested empirically; however, theoretically, it is known that there is a relationship between these variables.

Additionally, we demonstrated that gender moderates the relationship between entrepreneurial leadership and innovative work behavior. The impact was found to be stronger for women than for men. The standardized loading is 0.511 for women and 0.350 for men. This result is supported by studies that have found an incidence of gender as a moderator between transformational leadership and innovative work behavior (Reuvers et al., 2008). Moreover, our findings support Kimbu et al. (2021), who indicated that the universal gender assumptions that suggest that men can be more successful in management do not hold in certain contexts; these authors feminized trust and recognized it as favorable for the activities of entrepreneurial leadership. Likewise, Anambane and Adom (2018) described how culture and political structures, rather than an inability to manage, limit the business performance of female entrepreneurs. Hence, it is relevant to promote the creation of networks or clusters that are specifically aimed at promoting the innovative behavior of women as a way to drive business growth (Ngoasong and Kimbou, 2019).

This study is the first to evaluate empirically the mediating effect of work engagement on the relationship between entrepreneurial leadership and innovative work behavior. The evidence found in this study generates relevance for future studies to determine whether the sum of the professional skills of an employee is related to their innovative work behavior or whether it is limited to the aspect of generating creative ideas (Newman et al., 2017). Besides, the results of this novel study on the relationship between the aforementioned constructs create the opportunity for other researchers to validate them in other contexts and in other economic sectors, being able to incorporate gender as a control variable.

This research contributes results that can be taken as a guide for the entrepreneurial management of companies. It approaches an evaluation of the incidence that the three constructs of this study may have in organizations and the importance of their application in management as one of the guidelines to avoid failure (Baque et al., 2020; Kimbu et al., 2021).

References

- Afsar, B., Al-Ghazali, B. M., Cheema, S., & Javed, F. 2021. Cultural intelligence and innovative work behavior: the role of work engagement and interpersonal trust. *European Journal of Innovation Management*. <https://doi.org/10.1108/EJIM-01-2020-0008>
- Agarwal, U. 2014. Linking Justice, Trust and Innovative Work Behaviour to Work Engagement. *Personnel Review*, 43(1), 41–73. doi:10.1108/pr-02-2012-0019
- Agarwal, U. A., Datta, S., Blake-Beard, S., Bhargava, S. 2012. Linking LMX, Innovative Work Behaviour and Turnover Intentions: The Mediating Role of Work Engagement. *Career Development International*, 17(2), 208–230. doi:10.1108/13620431211241063
- Ahmad, I., Gao, Y. 2018. Ethical Leadership and Work Engagement. The Roles of Psychological Empowerment and Power Distance Orientation. *Management Decision*, 56(2), 1–16. doi:10.1108/md-02-2017-0107
- Akbari, M., Bagheri, A., Imani, S., Asadnezhad, M. 2021. Does Entrepreneurial Leadership Encourage Innovation Work Behavior? The Mediating Role of Creative Self-Efficacy and Support for Innovation. *European Journal of Innovation Management*, 24(1), 1–22. doi:10.1108/ejim-10-2019-0283
- Akram, T., Lei, S., Haider, M., Hussain, S. 2020. The Impact of Organizational Justice on Employee Innovative Work Behavior: Mediating Role of Knowledge Sharing. *Journal of Innovation & Knowledge*, 5(2), 117–129. <https://doi.org/10.1016/j.jik.2019.10.001>
- Alheet, A., Adwan, A., Areiqat, A., Zamil, A., & Saleh, M. (2021). The effect of leadership styles on employees' innovative work behavior. *Management Science Letters*, 11(1), 239-246. doi: 10.5267/j.msl.2020.8.010
- Amor, A. M., Abeal Vázquez, J. P., Faíña, J. A. 2020. Transformational Leadership and Work Engagement: Exploring the Mediating Role of Structural Empowerment. *European Management Journal*, 38(1), 169–178. doi:10.1016/j.emj.2019.06.007
- Anambane, G., Adom, K. 2018. Assessing the Role of Culture in Female Entrepreneurship in Contemporary Sub-Saharan Society: Insights from the Nabadam District of Ghana. *Journal of Developmental Entrepreneurship*, 23(3), 1850017. <https://doi.org/10.1142/S1084946718500176>
- Anwar, M., Clauss, T., Issah, W. B. 2021. Entrepreneurial Orientation and New Venture Performance in Emerging Markets: The Mediating Role of Opportunity Recognition. *Review of Managerial Science*, 1–29. <https://doi.org/10.1007/s11846-021-00457-w>
- Appelbaum, M., Cooper, H., Kline, R., Mayo-Wilson, E., Nezu, A., Rao, S. 2018. Journal Article Reporting Standards for Quantitative Research in Psychology: The APA Publications and

- Communications Board Task Force Report. *American Psychologist*, 73(1), 3–25.
<http://dx.doi.org/10.1037/amp0000191>
- Arbuckle, J. 2019. *Amos 26.0 User's Guide*. Chicago: IBM SPSS.
- Asif, M., Qing, M., Hwang, J., Shi, H. 2019. Ethical Leadership, Affective Commitment, Work Engagement, and Creativity: Testing a Multiple Mediation Approach. *Sustainability*, 11(16), 4489. doi:10.3390/su11164489
- Bagheri, A. 2017. The Impact of Entrepreneurial Leadership on Innovation Work Behavior and Opportunity Recognition in High-Technology SMEs. *Journal of High Technology Management Research*, 28(2), 159–166. doi: 10.1016/j.hitech.2017.10.003
- Bagheri, A., Akbari, M. 2018. The Impact of Entrepreneurial Leadership on Nurses' Innovation Behavior. *Journal of Nursing Scholarship*, 50(1), 28–35. doi: 10.1111/jnu.12354
- Bagheri, A., Harrison, C. 2020. Entrepreneurial Leadership Measurement: A Multi-dimensional Construct. *Journal of Small Business and Enterprise Development*, 27(4), 659–679. doi:10.1108/jsbed-01-2019-0027
- Bani-Melhem, S., Zeffane, R., Albaity, M. 2018. Determinants of Employees' Innovative Behavior. *International Journal of Contemporary Hospitality Management*, 30(3), 1601–1620. doi:10.1108/ijchm-02-2017-0079
- Baque-Cantos, M. A., Cedeño-Chenche, B. S., Chele-Chele, J. E., Gaona-Obando, V. B. 2020. Fracaso de las pymes: Factores desencadenantes, Ecuador 2020. *Revista Científica FIPCAEC (Fomento de la investigación y publicación en Ciencias Administrativas, Económicas y Contables)*. ISSN: 2588-090X. Polo de Capacitación, Investigación y Publicación (POCAIP), 5(4), 3–25. <https://doi.org/10.23857/fipcaec.v5i4.293>
- Bentler, P. (1990). Comparative Fit Indices in Structural Models. *Psychological Bulletin*, 107(2), 238–246. <https://doi.org/10.1037/0033-2909.107.2.238>
- Bernerth, J. B., Aguinis, H. 2015. A Critical Review and Best-Practice Recommendations for Control Variable Usage. *Personnel Psychology*, 69(1), 229–283. doi:10.1111/peps.12103
- Bogilović, S., Bortoluzzi, G., Černe, M., Ghasemzadeh, K., Žnidaršič, J. 2020. Diversity, Climate and Innovative Work Behavior. *European Journal of Innovation Management*, ahead-of-print. <https://doi.org/10.1108/EJIM-03-2020-0100>
- Bollen, K. 1989. *Structural Equations with Latent Variables*. John Wiley & Sons.
- Byrne, B. 2008. Testing for Multigroup Equivalence of a Measuring Instrument: A Walk through the Process. *Psicothema*, 2, 872–882. Recuperado a partir de <https://reunido.uniovi.es/index.php/PST/article/view/8744>
- Byrne, B. 2016. *Structural Equation Modeling with AMOS. Basic Concepts, Applications and Programming*. 3rd edition. Routledge.

- Cai, W., Lysova, E. I., Khapova, S. N., Bossink, B. A. G. 2018. Servant Leadership and Innovative Work Behavior in Chinese High-Tech Firms: A Moderated Mediation Model of Meaningful Work and Job Autonomy. *Frontiers in Psychology*, 9, 1–38. doi:10.3389/fpsyg.2018.01767
- Cai, W., Lysova, E. I., Khapova, S. N., Bossink, B. A. 2019. Does Entrepreneurial Leadership Foster Creativity among Employees and Teams? The Mediating Role of Creative Efficacy Beliefs. *Journal of Business and Psychology*, 34(2), 203–217. doi:10.1007/s10869-018-9536-y
- Camino-Mogro, S., Avilés-Terán, P. 2019. Panorama de la Inversión Empresarial en el Ecuador. Período: 2013–2018. Quito: Investigación y Estudios de la Superintendencia de Compañías, Valores y Seguros del Ecuador.
- Cho, E. 2016. Making Reliability Reliable: A Systematic Approach to Reliability Coefficients. *Organizational Research Methods*, 19(4), 651–682.
<https://doi.org/10.1177/1094428116656239>
- Chow, I. H. S. 2018. The Mechanism Underlying the Empowering Leadership–Creativity Relationship. *Leadership and Organization Development Journal*, 39(2), 202–217. doi:10.1108/lodj-03-2016-0060
- Cunningham, R. M., Kerr, G. B., Orobio, J., Munoz, F. M., Correa, A., Villafranco, N..., and Boom, J. A. (2019). Development of a Spanish version of the parent attitudes about childhood vaccines survey. *Human vaccines & immunotherapeutics*.
<https://doi.org/10.1080/21645515.2019.1578599>
- Darling, J., Keefe, M., Ross, J. 2007. Entrepreneurial Leadership Strategies and Values: Keys to Operational Excellence. *Journal of Small Business and Entrepreneurship*, 20(1), 41–54. doi:10.1080/08276331.2007.10593385
- Datta, S., Budhwar, P., Agarwal, U. A., & Bhargava, S. (2021). Impact of HRM practices on innovative behaviour: mediating role of talent development climate in Indian firms. *The International Journal of Human Resource Management*, 1-26.
<https://doi.org/10.1080/09585192.2021.1973063>
- De Jong, J., Den Hartog, D. 2008. Innovative Work Behavior: Measurement and Validation. Scales Research Reports H200820, EIM Business and Policy Research. Scientific Analysis of Entrepreneurship and SMEs, 1–27.
- De-la-Calle-Durán, M.-C., Rodríguez-Sánchez, J.-L. 2021. Employee Engagement and Wellbeing in Times of COVID-19: A Proposal of the 5Cs Model. *International Journal of Environmental Research and Public Health*, 18(10), 5470. doi:10.3390/ijerph18105470
- Ferrando, P., Lorenzo-Seva, U., Hernández-Dorado, A., Muñoz, J. 2022. Decálogo para el Análisis Factorial de los Ítems de un Test. *Psicothema*, 34(1), 7–17. doi: 10.7334/psicothema2021.456
- Finney, S., DiStefano, C. 2006. Non-normal and Categorical Data in Structural Equation Models. In Hancock, G., Mueller, R. (Eds.), *A Second Course in Structural Equation Modeling* (pp. 269–314). Information Age Publishing.

- Fontana, A., Musa, S. 2017. The Impact of Entrepreneurial Leadership on Innovation Management and its Measurement Validation. *International Journal of Innovation Science*, 9(1), 2–19. doi:10.1108/ijis-05-2016-0004
- Garg, S., Dhar, R. 2017. Employee Service Innovative Behavior. *International Journal of Manpower*, 38(2), 242–258. doi:10.1108/ijm-04-2015-0060
- Ge, J., Xu, H., Pellegrini, M. 2019. The Effect of Value Co-creation on Social Enterprise Growth: Moderating Mechanism of Environment Dynamics. *Sustainability*, 11(1), 250, 1–20. doi:10.3390/su11010250
- Giallonardo, L., Wong, C., Iwasiw, C. 2010. Authentic Leadership of Preceptors: Predictor of New Graduate Nurses' Work Engagement and Job Satisfaction. *Journal of Nursing Management*, 18, 993–1003. doi: 10.1111 /j.1365-2834.2010.01126.x
- Gomer, B., Jiang, G., Yuan, K. 2019. New Effect Size Measures for Structural Equation Modeling. *Structural Equation Modeling: A Multidisciplinary Journal*, 26(3), 371–389. doi:10.1080/10705511.2018.154523
- Gómez-Salgado, J., Domínguez-Salas, S., Romero-Martín, M., Romero, A., Coronado-Vázquez, V., & Ruiz-Frutos, C. 2021. Work engagement and psychological distress of health professionals during the COVID-19 pandemic. *Journal of nursing management*, 29(5), 1016-1025. <https://doi.org/10.1111/jonm.13239>
- Hair, J., Babin, B., Anderson, R., Black, W. 2018. *Multivariate Data Analysis*. 8th edition. CENGAGE.
- Hair, J., Babin, B., Krey, N. 2017. Covariance-Based Structural Equation Modeling in the Journal of Advertising: Review and Recommendations. *Journal of Advertising*, 46(1), 163–177.
- Hair, J., Sarstedt, M., Ringle, C., Gudergan, S. 2017. *Advanced Issues in Partial Least Squares Structural Equation Modeling (PLS-SEM)*. Thousand Oaks, CA: Sage.
- Hakanen, J. J., Rouvinen, P., Ylhäinen, I. 2021. The Impact of Work Engagement on Future Occupational Rankings, Wages, Unemployment, and Disability Pensions—A Register-Based Study of a Representative Sample of Finnish Employees. *Sustainability*, 13(4), 1626, 1–19. doi:10.3390/su13041626
- Hernaus, T., Maric, M., Černe, M. 2019. Age-Sensitive Job Design Antecedents of Innovative Work Behavior: The Role of Cognitive Job Demands. *Journal of Managerial Psychology*, 34(5), 368–382. doi:10.1108/jmp-10-2018-0478
- Hu, L., Bentler, P. 1999. Cutoff Criteria for Fit Indexes in Covariance Structure Analysis: Conventional Criteria versus New Alternatives. *Structural Equation Modeling*, 6, 1–55. doi:10.1080/10705519909540118
- IBM Corp. 2019. *IBM SPSS Statistics for Windows, Version 26.0*. Armonk, NY: IBM Corp.

- Iqbal, A., Nazir, T., Ahmad, M. 2022. Entrepreneurial Leadership and Employee Innovative Behavior: An Examination through Multiple Theoretical Lenses. *European Journal of Innovation Management*, 25(1), 173–190. <https://doi.org/10.1108/EJIM-06-2020-0212>
- Janssen, O. 2000. Job Demands, Perceptions of Effort–Reward Fairness, and Innovative Work Behavior. *Journal of Occupational and Organizational Psychology*, 73(3), 287–302. <https://doi.org/10.1348/096317900167038>
- Kahn, W. 1990. Psychological Conditions of Personal Engagement and Disengagement at Work. *Academy of Management Journal*, 33(4), 692–724. doi:10.2307/256287
- Kanter, R. 1988. When a Thousand Flowers Bloom: Structural, Collective, and Social Conditions for Innovation in Organizations. In B. Staw, L. Cummings (Eds.), *Research in Organizational Behavior* (Vol. 16, pp. 169–211). JAI Press.
- Karatepe, O. M., Rezapouraghdam, H., Assannia, R. 2020. Job Insecurity, Work Engagement and Their Effects on Hotel Employees’ Non-green and Nonattendance Behaviors. *International Journal of Hospitality Management*, 87(102472), 1–12. doi: 10.1016/j.ijhm.2020.102472
- Kimbu, A. N., De Jong, A., Adam, I., Ribeiro, M. A., Afenyo-Agbe, E., Adeola, O., Figueroa-Domecq, C. 2021. Recontextualising Gender in Entrepreneurial Leadership. *Annals of Tourism Research*, 88(103176), 1–12. doi: 10.1016/j.annals.2021.103176
- Kline, R. 2016. *Principles and Practice of Structural Equation Modeling*. 4th edition. New York: Guilford Press.
- Knezović, E., Drkić, A. 2020. Innovative Work Behavior in SMEs: The Role of Transformational Leadership. *Employee Relations*, 43(2), 398–415. <https://doi.org/10.1108/ER-03-2020-0124>
- Kwon, K., Kim, T. 2020. An integrative literature review of employee engagement and innovative behavior: Revisiting the JD-R model. *Human Resource Management Review*, 30(2). <https://doi.org/10.1016/j.hrmr.2019.100704>
- Leal, S., Salomón, J., Rivera, J. 2021. Impact of Authentic Leadership on Work Engagement and Organizational Citizenship Behavior: The Meditating Role of Motivation for Work. *International Journal of Economics and Business Administration*, 9(3), 3–31. doi: 10.35808/ijeba/716
- Li, C., Makhdoom, H., Asim, S. 2020. Impact of Entrepreneurial Leadership on Innovative Work Behavior: Examining Mediation and Moderation Mechanisms. *Psychology Research and Behavior Management*, 13, 105–118. doi:10.2147/PRBM.S236876
- Lisbona, A., Palaci, F., Salanova, M., Frese, M. 2018. The Effects of Work Engagement and Self-Efficacy on Personal Initiative and Performance. *Psicothema*, 30(1), 89–96. doi: 10.7334/psicothema2016.245
- Liu, J., Zhou, X., & Wang, Q. (2022). The influence of entrepreneurial leadership on employee improvisation in new ventures: based on cognitive-affective processing system framework. *Kybernetes*. <https://doi.org/10.1108/K-10-2021-0933>

- MacCallum, R., Browne, M., Sugawara, H. 1996. Power Analysis and Determination of Sample Size for Covariance Structure Modeling of Fit Involving a Particular Measure of Model. *Psychological Methods*, 13(2), 130–149. <https://doi.org/10.1037/1082-989X.1.2.130>
- MacCallum, R., Widaman, K., Preacher, K., Hong, S. 2001. Sample Size in Factor Analysis: The Role of Model Error. *Multivariate Behavioral Research*, 36(4), 611–637. https://doi.org/10.1207/S15327906MBR3604_06
- Mardia, K. 1970. Measures of Multivariate Skewness and Kurtosis with Applications. *Biometrika*, 57(3), 519–530. doi: 10.1093/biomet/57.3.519
- Mehmood, M. S., Jian, Z., Akram, U., Tariq, A. 2021. Entrepreneurial Leadership: The Key to Develop Creativity in Organizations. *Leadership & Organization Development Journal*, 1–20. doi: 10.1108/LODJ-01-2020-0008
- Montani, F., Vandenberghe, C., Khedhaouria, A., Courcy, F. 2019. Examining the Inverted U-Shaped Relationship between Workload and Innovative Work Behavior: The Role of Work Engagement and Mindfulness. *Human Relations*, 73(1), 59–93. doi:10.1177/0018726718819055
- Mulligan, R.; Ramos, J.; Martín, P.; Zornoza, A. 2021. Inspiring Innovation: The Effects of Leader-Member Exchange (LMX) on Innovative Behavior as Mediated by Mindfulness and Work Engagement. *Sustainability* 2021, 13, 5409. <https://doi.org/10.3390/su13105409>
- Neuber, L., Englitz, C., Schulte, N., Forthmann, B., & Holling, H. (2022). How work engagement relates to performance and absenteeism: a meta-analysis. *European Journal of Work and Organizational Psychology*, 31(2), 292-315. <https://doi.org/10.1080/1359432X.2021.1953989>
- Newman, A., Neesham, C., Manville, G., Tse, H. H. M. 2017. Examining the Influence of Servant and Entrepreneurial Leadership on the Work Outcomes of Employees in Social Enterprises. *International Journal of Human Resource Management*, 29(20), 1–22. doi:10.1080/09585192.2017.1359792
- Newman, A., Tse, H. H. M., Schwarz, G., Nielsen, I. 2018. The Effects of Employees' Creative Self-efficacy on Innovative Behavior: The Role of Entrepreneurial Leadership. *Journal of Business Research*, 89, 1–9. doi: 10.1016/j.jbusres.2018.04.001
- Ngoasong, M. Z., Kimbu, A. N. 2019. Why Hurry? The Slow Process of High Growth in Women-Owned Businesses in a Resource-Scarce Context. *Journal of Small Business Management*, 57(1), 40–58. <https://doi.org/10.1111/jsbm.12493>
- Nguyen, P. V., Huynh, H. T. N., Lam, L. N. H., Le, T. B., & Nguyen, N. H. X. 2021. The impact of entrepreneurial leadership on SMEs' performance: the mediating effects of organizational factors. *Heliyon*, 7(6), e07326. <https://doi.org/10.1016/j.heliyon.2021.e07326>
- Oh, J., Cho, D., Lim, D. H. 2018. Authentic Leadership and Work Engagement: The Mediating Effect of Practicing Core Values. *Leadership & Organization Development Journal*, 39(2), 276–290. doi:10.1108/lodj-02-2016-0030

- Park, Y. K., Song, J. H., Yoon, S. W., Kim, J. 2014. Learning Organization and Innovative Behavior. *European Journal of Training and Development*, 38(1/2), 75–94. doi:10.1108/ejtd-04-2013-0040
- Rahmadani, V. G., & Schaufeli, W. B. 2022. Engaging Leadership and Work Engagement as moderated by “Diuwongke”: An Indonesian study. *The International Journal of Human Resource Management*, 33(7), 1267-1295. doi: 10.1080/09585192.2020.1799234
- Reina-Tamayo, A. M., Bakker, A. B., & Derks, D. (2018). The work engagement–performance link: an episodic perspective. *Career Development International*, 23(5), 478-496. doi:10.1108/cdi-10-2017-0179
- Renko, M., El Tarabishy, A., Carsrud, A. L., Brännback, M. 2015. Understanding and Measuring Entrepreneurial Leadership Style. *Journal of Small Business Management*, 53(1), 54–74. doi:10.1111/jsbm.12086
- Reuvers, M., van Engen, M. L., Vinkenburg, C. J., Wilson-Evered, E. 2008. Transformational Leadership and Innovative Work Behaviour: Exploring the Relevance of Gender Differences. *Creativity and Innovation Management*, 17(3), 227–244. doi:10.1111/j.1467-8691.2008.00487. x.
- Saeed, B. B., Afsar, B., Cheema, S., Javed, F. 2018. Leader–Member Exchange and Innovative Work Behavior: The Role of Creative Process Engagement, Core Self-evaluation, and Domain Knowledge. *European Journal of Innovation Management*, 22(1), 105–124. doi: 10.1108/EJIM-11-2017-0158
- Salessi, S. 2021. Comportamiento innovador en el trabajo: Análisis factorial confirmatorio de la Escala de Janssen. *Interdisciplinaria*, 38(1), 7–21. <http://dx.doi.org/10.16888/interd.2021.38.1.1>.
- Schaufeli, W. B. 2015. Engaging Leadership in the Job Demands–Resources Model. *Career Development International*, 20(5), 446–463. doi:10.1108/cdi-02-2015-0025
- Schaufeli, W. 2021. Engaging Leadership: How to Promote Work Engagement? *Frontiers in psychology*, 12. doi: 10.3389/fpsyg.2021.754556
- Schaufeli, W., Bakker, A. 2003. Utrecht Work Engagement Scale: Preliminary Manual. Occupational Health Psychology Unit, Utrecht University. Retrieved from https://www.wilmarschaufeli.nl/publications/Schaufeli/Test%20Manuals/Test_manual_UWES_English.pdf
- Schaufeli, W. B., Bakker, A. B. 2004. Job Demands, Job Resources, and Their Relationship with Burnout and Engagement: A Multi-Sample Study. *Journal of Organizational Behavior*, 25(3), 293–315. doi:10.1002/job.248
- Schaufeli, W. B., Salanova, M., González-Romá, V., Bakker, A. B. 2002. The Measurement of Engagement and Burnout: A Two Sample Confirmatory Factor Analytic Approach. *Journal of Happiness*, 3(1), 71–92. doi:10.1023/A:1015630930326

- Shujahat, M., Ali, B., Nawaz, F., Durst, S., Kianto, A. 2018. Translating the Impact of Knowledge Management into Knowledge-Based Innovation: The Neglected and Mediating Role of Knowledge Worker Satisfaction. *Human Factors and Ergonomics in Manufacturing and Service Industries*, 28(4), 200–212. <https://doi.org/10.1002/hfm.20735>
- Verma, J., Verma, P. 2020. Determining Sample Size and Power in Research Studies. A Manual for Researchers. Springer Nature Singapore Pte Ltd. <https://doi.org/10.1007/978-981-15-5204-5>
- Wang, Z., Cui, T., Cai, S., & Ren, S. 2022. How and when high-involvement work practices influence employee innovative behavior. *International Journal of Manpower*.
<https://doi.org/10.1108/IJM-11-2020-0531>
- Wang, Z., Gao, M., Panaccio, A. 2020. A Self-Determination Approach to Understanding Individual Values as an Interaction Condition on Employees' Innovative Work Behavior in the High-Tech Industry. *Journal of Creative Behavior*, 55(1), 183–198. doi:10.1002/jocb.444



Chapter II. Conclusions and Recommendations

Conclusions

The findings of this research demonstrated that the five proposed hypotheses are statistically significant. It was found a statistically significant positive relationship between entrepreneurial leadership and work engagement, with a p -value <0.001 , which fills the empirical gap that was identified in the literature review of this study. Therefore, hypothesis 1 (H1) was accepted. This finding is supported by the research carried out by Cai et al. (2018), Leal et al. (2021), and Lisbona et al. (2018) on the different types of leadership and work engagement. The results also revealed that the positive relationship between entrepreneurial leadership and innovative behavior is statistically significant, with a p -value <0.001 , validating hypothesis 2 (H2). Similar results were obtained by Li et al. (2020) and Newman et al. (2018) in China, Newman et al. (2017) in Australia, Canada, and the United Kingdom, and Bagheri & Akbari (2018) in Iran.

Likewise, there is a positive statistically significant impact of work engagement on innovative work behavior, which leads to the acceptance of hypothesis 3 (H3). This finding is consistent with other research that has presented the same result, showing that committed employees experience emotions such as happiness, joy, interest, and enthusiasm in their work, which constitute the motivational basis on which to promote innovative work behavior (Agarwal et al., 2012). Additionally, engaged employees may experience a better relationship with their supervisors, ensuring greater support for new ideas (Garg & Dhar, 2017; Montani et al., 2019).

Regarding mediation, hypothesis 4 (H4) was accepted. It was verified that work engagement indeed has a statistically significant mediating effect on the relationship between entrepreneurial leadership and innovative work behavior. Empirical results have shown separately that entrepreneurial leadership has a positive effect on innovative work behavior

(Li et al., 2020) and that work engagement produces a positive effect on innovative work behavior (Agarwal, 2014; Garg & Dhar, 2017). The link between the three constructs has not previously been tested empirically. However, theoretically, it is known that there is a relationship between these variables.

Additionally, it was demonstrated that gender moderates the relationship between entrepreneurial leadership and innovative work behavior. The impact was found to be stronger for women than for men. The standardized loading is 0.511 for women and 0.350 for men. This result is supported by studies that have found an incidence of gender as a moderator between transformational leadership and innovative work behavior (Reuvers et al., 2008). Moreover, our findings support Kimbu et al. (2021), who indicated that the universal gender assumptions that suggest that men can be more successful in management do not hold in certain contexts; these authors feminized trust and recognized it as favorable for the activities of entrepreneurial leadership. Likewise, Anambane & Adom (2018) described how culture and political structures, rather than an inability to manage, limit the business performance of female entrepreneurs. Hence, it is relevant to promote the creation of networks or clusters that are specifically aimed at promoting the innovative behavior of women as a way to drive business growth (Ngoasong & Kimbou, 2019).

Implications

The relationship between entrepreneurial leadership and innovative work behavior was already encountered by Newman et al. (2017), and the mediation effect of creative self-efficacy and passion for invention in that relationship was found by Bagheri et al. (2020). However, the mediation effect of work engagement on the relationship between entrepreneurial leadership and innovative work behavior has not been examined before. Theoretically, it is relevant because a new concept of the link between those two variables has been developed in this study. In this way, more factors affecting innovative work behavior

have been revealed. Hence, the theoretical implication of this study refers to the construction of a novel conceptual model and the finding of empirical evidence of the mediating effect of work engagement on the relationship between entrepreneurial leadership and innovative work behavior.

Regarding the practical implications, the results can be taken as a guide for the entrepreneurial management of firms. It focuses an evaluation of the incidence that the three constructs of this study may have in organizations and the importance of their application in management as one of the guidelines to avoid failure (Baque et al., 2020; Kimbu et al., 2021). This research highlights the importance of entrepreneurial leadership to promote work engagement, and innovative work behavior. The importance of developing innovative work behavior in a firm comes from the fact that innovation can generate competitive advantage for firms and increase performance (Castillo-Vergara & García-Pérez-de-Lema, 2021). In this study, the manufacturing sector is analyzed, this is a sector that has a great amount of firms and competition can be harsh, acquiring competitive advantage over other firms is fundamental. Therefore, it is especially relevant for manufacturing firms to know the process to acquire this competitive advantage resultant from innovative work behavior.

Recommendations

The evidence found in this study generates relevance for future studies to determine whether the sum of the main professional skills of an employee is related to their innovative work behavior or whether it is limited to the aspect of generating creative ideas (Newman et al., 2017). Furthermore, the results of this novel study on the relationship between the aforementioned constructs create the opportunity for other researchers to validate them in other contexts and in other economic sectors, being able to incorporate gender as a control variable.

Specifically, it would be very interesting to analyze how these three variables interact in other sectors, such as, agriculture, construction, financial services, and others. As mentioned before, for manufacturing firms, the innovation process is relevant to acquire a better position in the market, but it may not be relevant for other types of firms.

Additionally, the entrepreneurial leadership may not be as effective in other countries with other cultural and economic context, or the process to acquire this type of leadership may be different between developed and developing countries (Harrison, Burnard & Paul, 2017). All of these factors may be interesting to analyze.

Therefore, for future research, the analysis of the three variables in other countries (developed and developing), economic sectors, and size of firms would be relevant to discuss. In the case of the country analyzed in this study, it would also be relevant to determine if these variables behave similarly and are important for other cities (in this study only the 2 biggest cities were studied).

References

- Agarwal, U. A., Datta, S., Blake-Beard, S., & Bhargava, S. (2012). Linking LMX, innovative work behaviour and turnover intentions: the mediating role of work engagement. *Career Development International*, 17(2), 208-230. doi:10.1108/13620431211241063
- Agarwal, U. (2014). Linking justice, trust and innovative work behaviour to work engagement. *Personnel Review*, 43(1), 41–73. doi:10.1108/pr-02-2012-0019.
- Amor, A. M., Abeal Vázquez, J. P., & Faíña, J. A. (2019). Transformational leadership and work engagement: Exploring the mediating role of structural empowerment. *European Management Journal*, 38(1), 169-178. doi:10.1016/j.emj.2019.06.007
- Anambane, G. & Adom, K. (2018). Assessing the Role of Culture in Female Entrepreneurship in Contemporary Sub-Saharan Society: Insights from the Nabadam District of Ghana. *Journal of Developmental Entrepreneurship*, 23(3), 1850017. <https://doi.org/10.1142/S1084946718500176>
- Bagheri, A. (2017). The impact of entrepreneurial leadership on innovation work behavior and opportunity recognition in high-technology SMEs. *Journal of High Technology Management Research*, 28(2), 159-166. doi:10.1016/j.hitech.2017.10.003
- Bagheri, A. & Akbari, M. (2018). The impact of entrepreneurial leadership on nurses' innovation behavior. *Journal of Nursing Scholarship*, 50(1), 28-35. doi: 10.1111/jnu.12354
- Baque-Cantos, M. A., Cedeño-Chenche, B. S., Chele-Chele, J. E. & Gaona-Obando, V. B. (2020). Fracaso de las pymes: Factores desencadenantes, Ecuador 2020. *Revista Científica FIPCAEC (Fomento de la investigación y publicación en Ciencias Administrativas, Económicas y Contables)*, 5(4), 3–25. <https://doi.org/10.23857/fipcaec.v5i4.293>
- Byrne, B. (2016). Structural equation modeling with AMOS. *Basic concepts, applications and programming*, third edition. New York, EEUU. Routledge.

- Cai, W., Lysova, E. I., Khapova, S. N., & Bossink, B. A. G. (2018). Servant leadership and innovative work behavior in chinese high-tech firms: A moderated mediation model of meaningful work and job autonomy. *Frontiers in Psychology*, 9, 1-38.
doi:10.3389/fpsyg.2018.01767
- Castillo-Vergara, M., & García-Pérez-de-Lema, D. (2021). Product innovation and performance in SME's: the role of the creative process and risk taking. *Innovation*, 23(4), 470-488. <https://doi.org/10.1080/14479338.2020.1811097>
- Garg, S., & Dhar, R. (2017). Employee service innovative behavior. *International Journal of Manpower*, 38(2), 242–258. doi:10.1108/ijm-04-2015-0060
- Hair, J; Babin, B; Anderson, R y Black, W. (2018). *Multivariate Data Analysis*, eighth Edition. Cengage.
- Harrison, C., Burnard, K., & Paul, S. (2017). Entrepreneurial leadership in a developing economy: a skill-based analysis. *Journal of Small Business and Enterprise Development*. <https://doi.org/10.1108/JSBED-05-2017-0160>
- Horn, J. (1991). Comments on “Issues in Factorial Invariance”. In L. M. Collins and J. L. Horn (eds.), *Best Methods for the Analysis of Change*. Washington, DC: American Psychological Association, pp. 114–25.
- Janssen, O. (2000). Job demands, perceptions of effort-reward fairness, and innovative work behavior. *Journal of Occupational and Organizational Psychology*, 73(3), 287–302.
<https://doi.org/10.1348/096317900167038>
- Kimbu, A. N., De Jong, A., Adam, I., Ribeiro, M. A., Afenyo-Agbe, E., Adeola, O., & Figueroa-Domecq, C. (2021). Recontextualising gender in entrepreneurial leadership. *Annals of Tourism Research*, 88, 103176, 1-12. doi:10.1016/j.annals.2021.103176

- Leal, S., Salomón, J. & Rivera, J (2021). Impact of authentic leadership on work engagement and organizational citizenship behavior: The meditating role of motivation for work. *International Journal of Economics and Business Administration*, 9(3), 3-31. doi: 10.35808/ijeba/716
- Li, C., Makhdoom, H., & Asim, S. (2020). Impact of entrepreneurial leadership on innovative work behavior: Examining mediation and moderation mechanisms. *Psychology research and behavior management*, 13, 105–118. doi:10.2147/PRBM.S236876
- Lisbona, A., Palaci, F., Salanova, M. & Frese, M. (2018). The effects of work engagement and self-efficacy on personal initiative and performance. *Psicothema*, 30(1), 89-96. doi: 10.7334/psicothema2016.245
- Montani, F., Vandenberghe, C., Khedhaouria, A., & Courcy, F. (2019). Examining the inverted U-shaped relationship between workload and innovative work behavior: The role of work engagement and mindfulness. *Human Relations*, 73(1), 59–93. doi:10.1177/0018726718819055
- Newman, A., Neesham, C., Manville, G., & Tse, H. H. M. (2017). Examining the influence of servant and entrepreneurial leadership on the work outcomes of employees in social enterprises. *International Journal of Human Resource Management*, 29(20), 1-22. doi:10.1080/09585192.2017.1359792
- Newman, A., Tse, H.H.M., Schwarz, G., & Nielsen, I. (2018). The effects of employees' creative self-efficacy on innovative behavior: The role of entrepreneurial leadership. *Journal of Business Research*, 89, 1-9. doi:10.1016/j.jbusres.2018.04.001
- Ngoasong, M. Z., Kimbu, A. N. 2019. Why Hurry? The Slow Process of High Growth in Women-Owned Businesses in a Resource-Scarce Context. *Journal of Small Business Management*, 57(1), 40–58. <https://doi.org/10.1111/jsbm.12493>

- Renko, M., El Tarabishy, A., Carsrud, A. L., & Brännback, M. (2015). Understanding and measuring entrepreneurial leadership style. *Journal of Small Business Management*, 53(1), 54-74. doi:10.1111/jsbm.12086
- Reuvers, M., van Engen, M. L., Vinkenbug, C. J., & Wilson-Evered, E. (2008). Transformational leadership and innovative work behaviour: Exploring the relevance of gender differences. *Creativity and Innovation Management*, 17(3), 227–244. doi:10.1111/j.1467-8691.2008.00487.x).
- Salessi, S. (2021). Comportamiento innovador en el trabajo: Análisis factorial confirmatorio de la Escala de Janssen. *Interdisciplinaria*, 38(1), 7-21. <http://www.redalyc.org/articulo.oa?id=18065114001>
- Schaufeli, W. y Bakker, A. (2003). Utrecht. Work Engagement Scale. Preliminary Manual. Utrecht, Países Bajos: Occupational Health Psychology Unit. Utrecht University.
- Wang, Z., Gao, M., & Panaccio, A. (2020). A self-determination approach to understanding individual values as an interaction condition on employees' innovative work behavior in the high-tech industry. *Journal of Creative Behavior*, 55(1), 183–198. doi:10.1002/jocb.444

Appendix A: Acceptance letter of the research article



ISSN: 2241-4754

www.ijeaba.com

International Journal of Economics & Business Administration

11/05/2022

REF: Paper Acceptance

AD/AG/ 2022/11/05

General Editor and Founder

Prof. E. Thalassinos,
European Chair Jean Monnet,
Dept. of Maritime Studies, University of Piraeus,
Gr. Labraki 21 & Distomou, 18533, Piraeus, Greece
Tel: 00302104142543, Fax: 00302104142571,
Email: thalassinos@ersi.eu, thalassi@unipi.gr

Editors (from 2016)

Allegret J. P., Université Paris Ouest Nanterre La
Défense, FR,
jallegret@u-paris10.fr

Bonitsis T. H., New Jersey Institute of Technology,
USA,
bonitsis@admin.njit.edu

Faïña A., University of Coruña, SP,
faina@udc.es

Hanappi H., University of Technology of Vienna,
AT,
hanappi@tuwien.ac.at

Katsikides S., University of Cyprus, CY,
savvas@ucy.ac.cy

Malindretos J., William Paterson University, New
Jersey, USA, jmalindre@optonline.net

Malliaris T., Loyola University Chicago, USA,
tmallia@luc.edu

Associate Editors (from 2016)

Akarca A., University of Illinois, Chicago, USA,
Akarca@uic.edu

Hassapis K., University of Cyprus, CY,
kristis@ucy.ac.cy

Kallianiotis I. N., Professor of Finance, Scranton
University, USA, jnk3533@scranton.edu

Pelagidis T., University of Piraeus, GR,
pelagidi@unipi.gr

Staikouras S. K., Cass Business School, UK,
sks@city.ac.uk

Book Review Editors (from 2016)

Kondonassis A. J., University of Oklahoma, USA,
A.J.Kondonassis-1@ou.edu

Dear Colleague, Dear Nory Pinela Morán,

With this letter I would like to inform you that your paper submitted to IJEBA titled "Entrepreneurial Leadership, Work Engagement, and Innovative Work Behavior: The Moderating Role of Gender" co-authored with Ruben Guevara Moncada and Mary Armijos Yambay has been accepted for publication in the Journal.

After evaluation by two referees, the Scientific Committee has decided to publish your paper in Volume X, Issue 2, 2022. The APC of your article is 900 euro and this is an open access publication.

IJEBA is an international journal indexed in many international data bases.

Thank you for considering the *International Journal of Economics & Business Administration* as a possible outlet for your research.

Yours sincerely,

International Strategic Management Association
Αρσίου 96 Αθήνα 14. 108 77
Η.Τ. Μη Κερδοσκοπική Τηλ. 3833347
ΑΦΜ : 080180931 ΔΟΥ : Γ' ΑΘΗΝΩΝ

Prof. E. Thalassinos
General Editor IJEBA